

1 A·M区平面图配置图

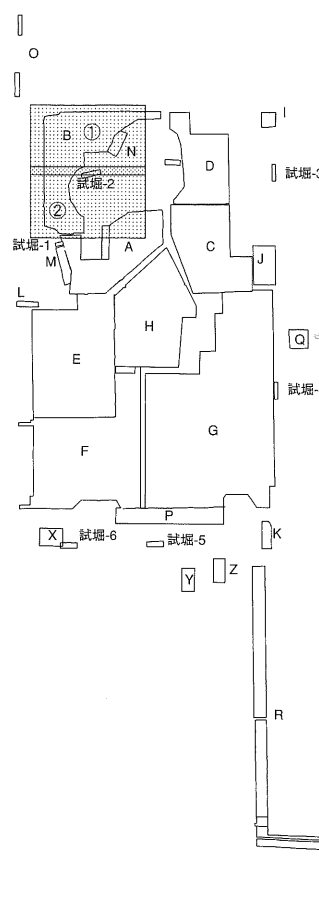

- ① 图版 129
- 图版 130
- 图版 131
- 图版 132



2 B·N区平面图配置图



- ① 图版 138
- 图版 140
- 图版 141
- 图版 143
- ② 图版 139
- 图版 142

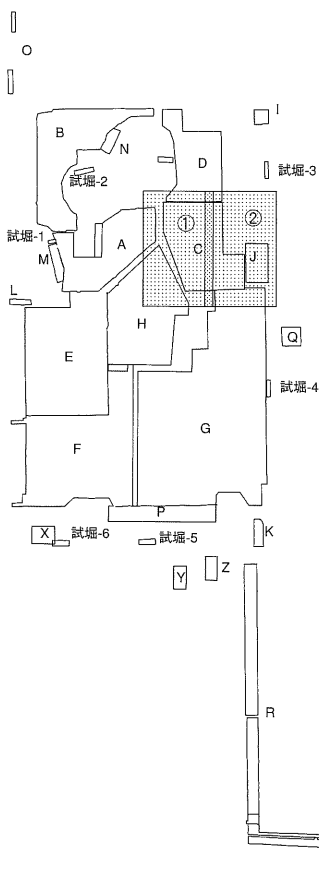

3 C区平面图配置图



- ① 图版 147
- 图版 149
- 图版 151
- 图版 153
- ② 图版 148
- 图版 150
- 图版 152
- 图版 154

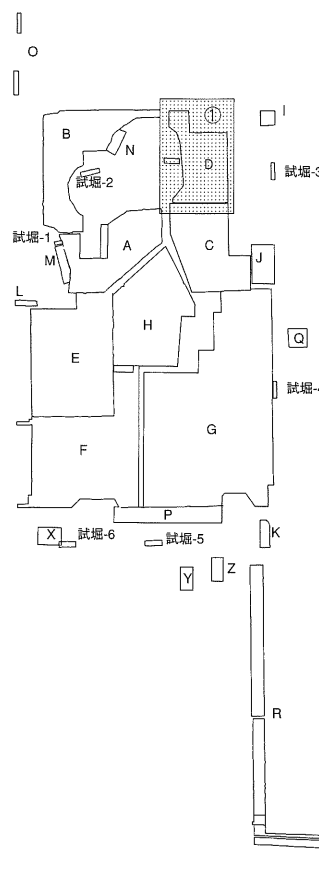

4 D区平面图配置图



- ① 图版 160
- 图版 161
- 图版 162
- 图版 163

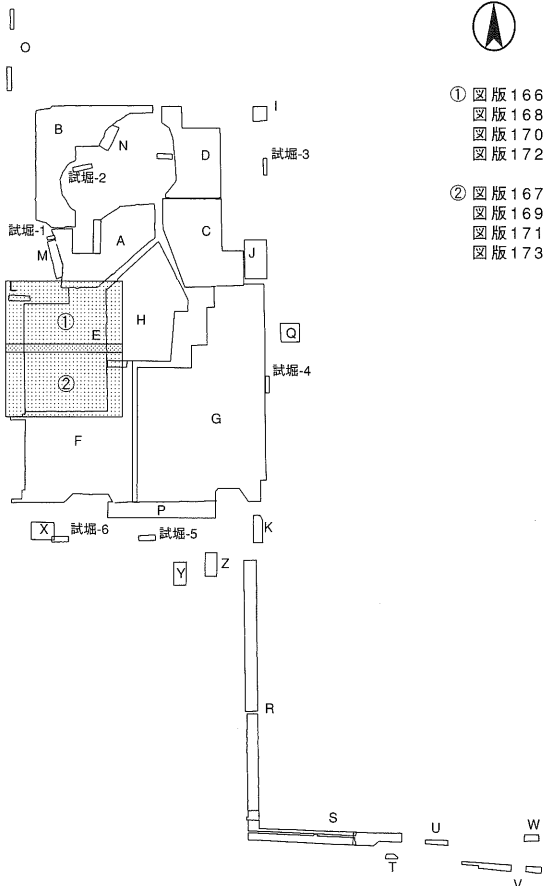

- ① 图版 166  
图版 168  
图版 170  
图版 172
- ② 图版 167  
图版 169  
图版 171  
图版 173

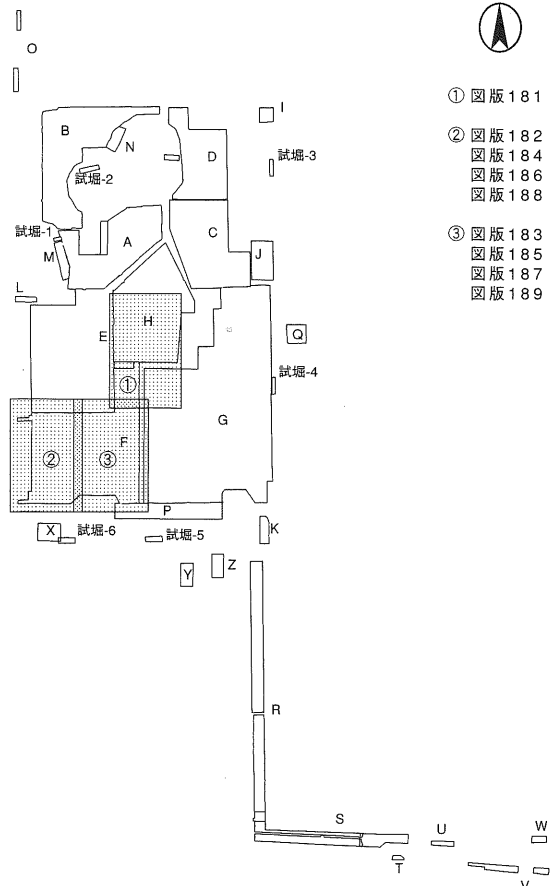

- ① 图版 181
- ② 图版 182  
图版 184  
图版 186  
图版 188
- ③ 图版 183  
图版 185  
图版 187  
图版 189

1 E·L区平面图配置图

2 F区平面图配置图

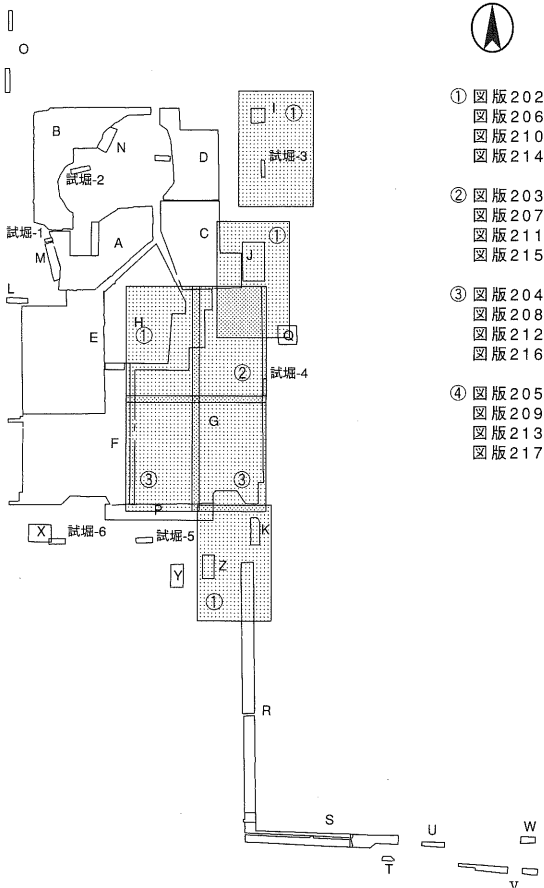

- ① 图版 202  
图版 206  
图版 210  
图版 214
- ② 图版 203  
图版 207  
图版 211  
图版 215
- ③ 图版 204  
图版 208  
图版 212  
图版 216
- ④ 图版 205  
图版 209  
图版 213  
图版 217

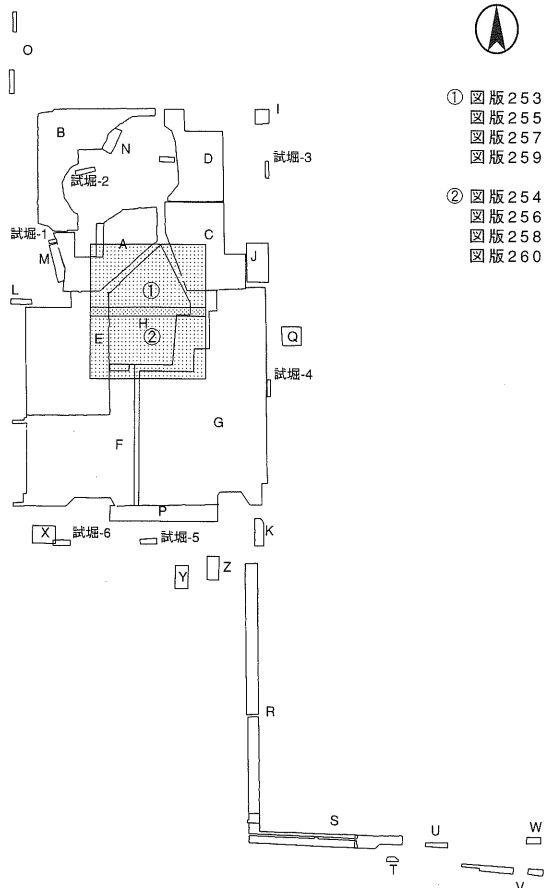

- ① 图版 253  
图版 255  
图版 257  
图版 259
- ② 图版 254  
图版 256  
图版 258  
图版 260

3 G·I·J·K区平面图配置图

4 H区平面图配置图

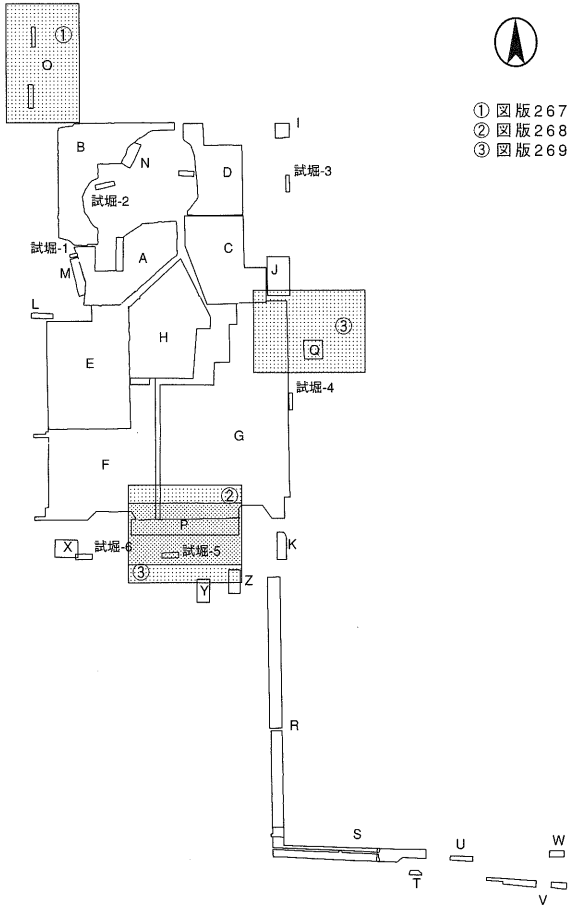

1 O・P・Q区平面図配置図



- ① 図版 267
- ② 図版 268
- ③ 図版 269

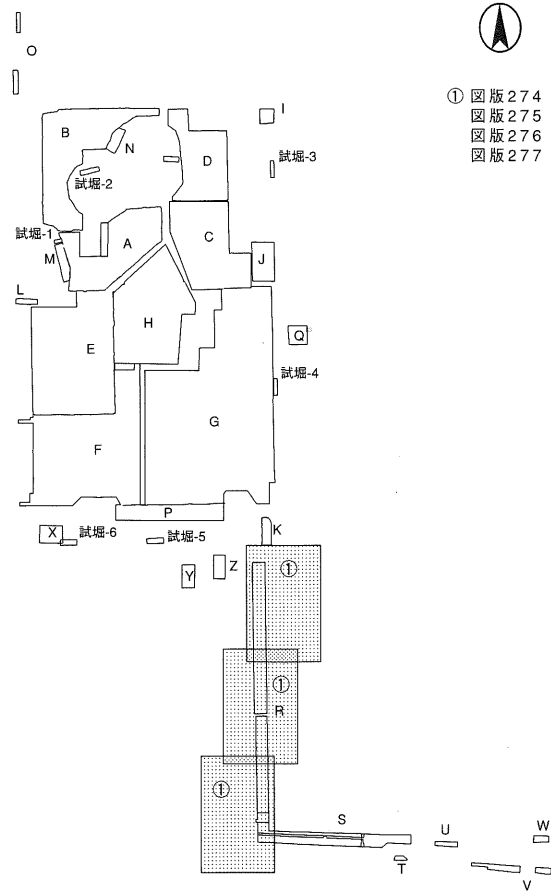

2 R区平面図配置図



- ① 図版 274
- 図版 275
- 図版 276
- 図版 277

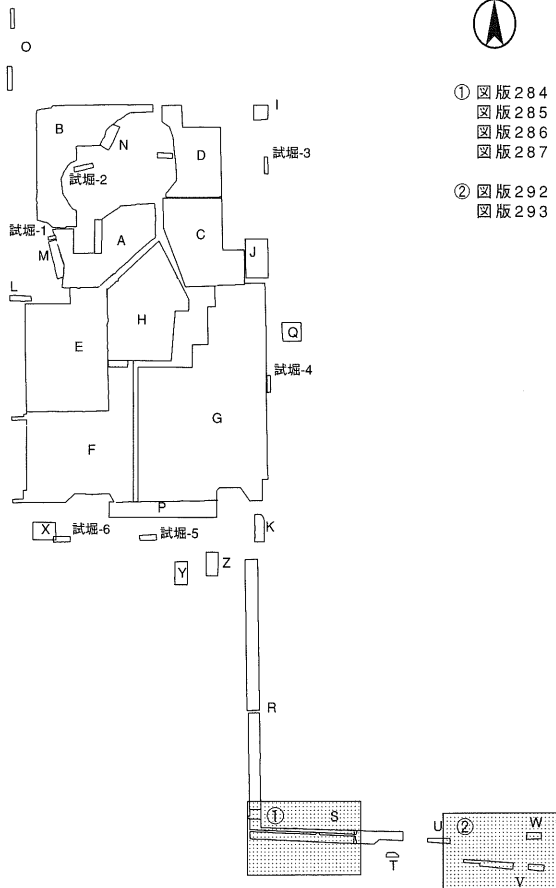

3 S区西部・V・W区平面図配置図



- ① 図版 284
- 図版 285
- 図版 286
- 図版 287
- ② 図版 292
- 図版 293

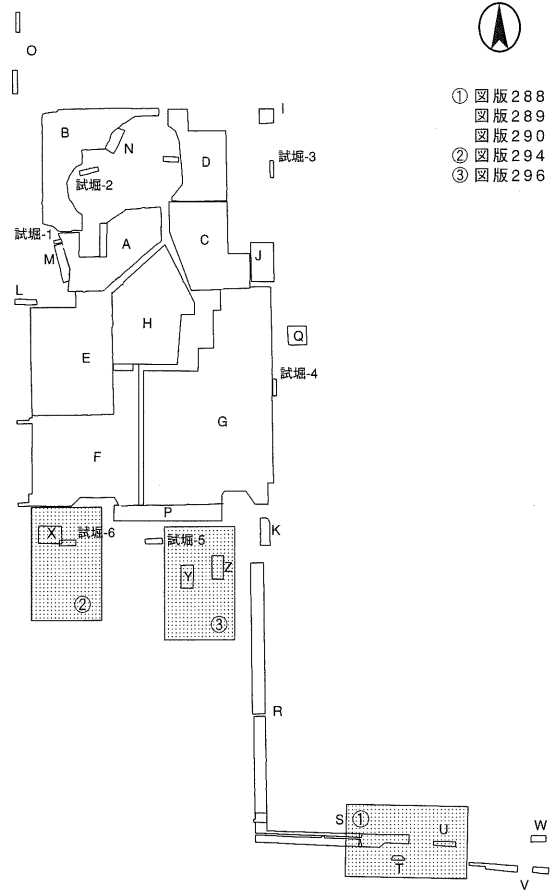

4 S区東部・T・U・X・Y・Z区平面図配置図



- ① 図版 288
- 図版 289
- 図版 290
- ② 図版 294
- ③ 図版 296

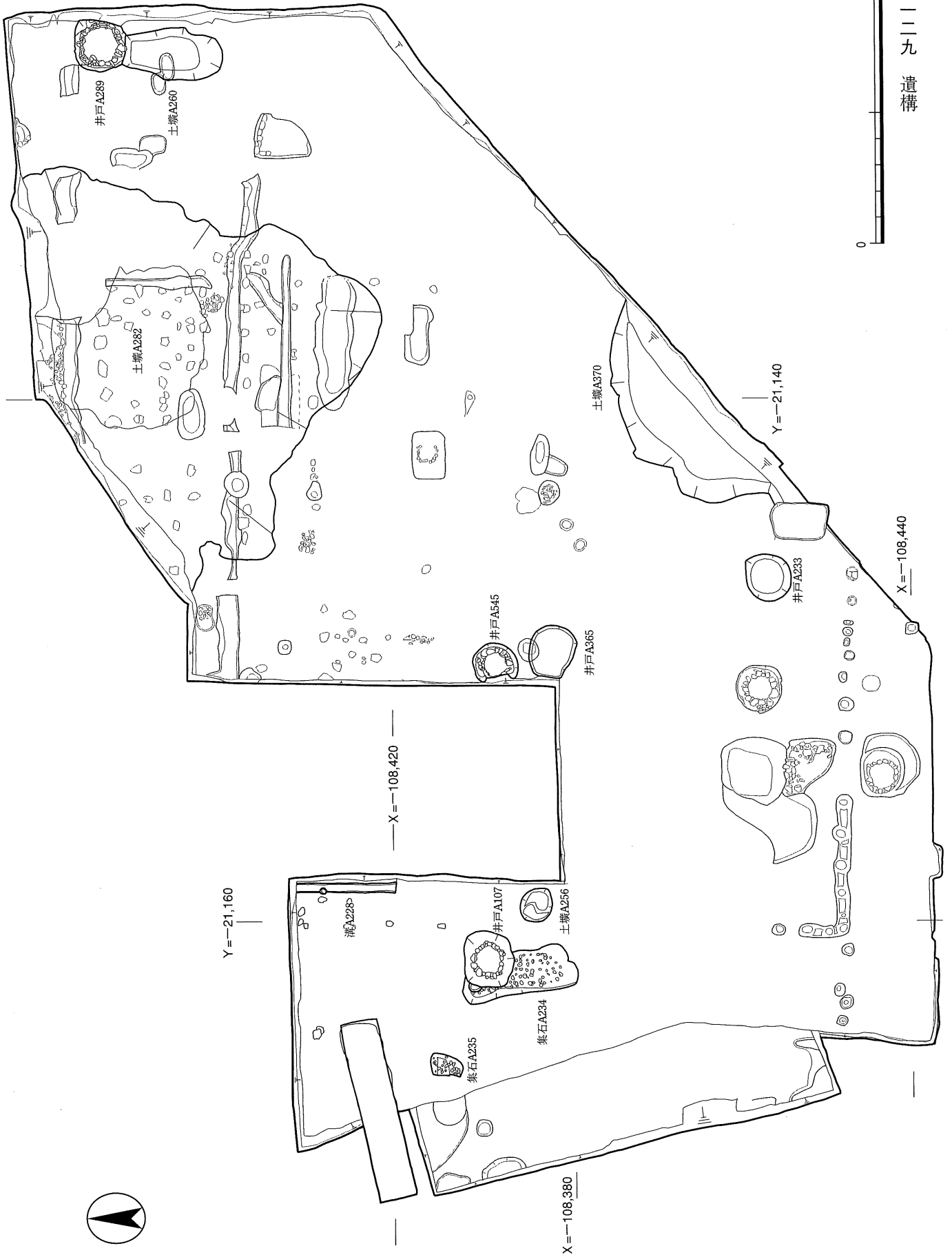

A・M区桃山期遺構平面図

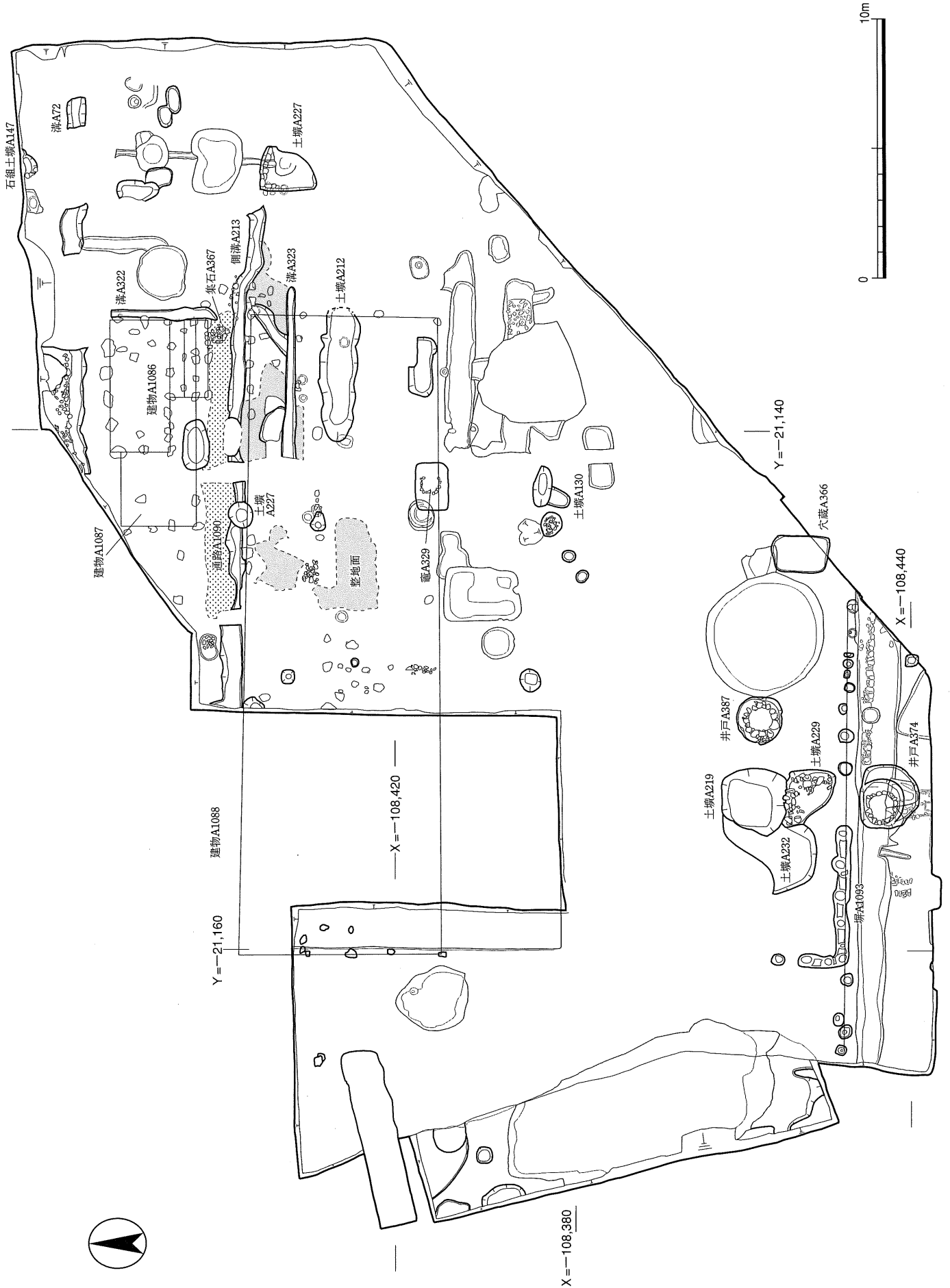

A・M区江戸時代前期遺構平面図

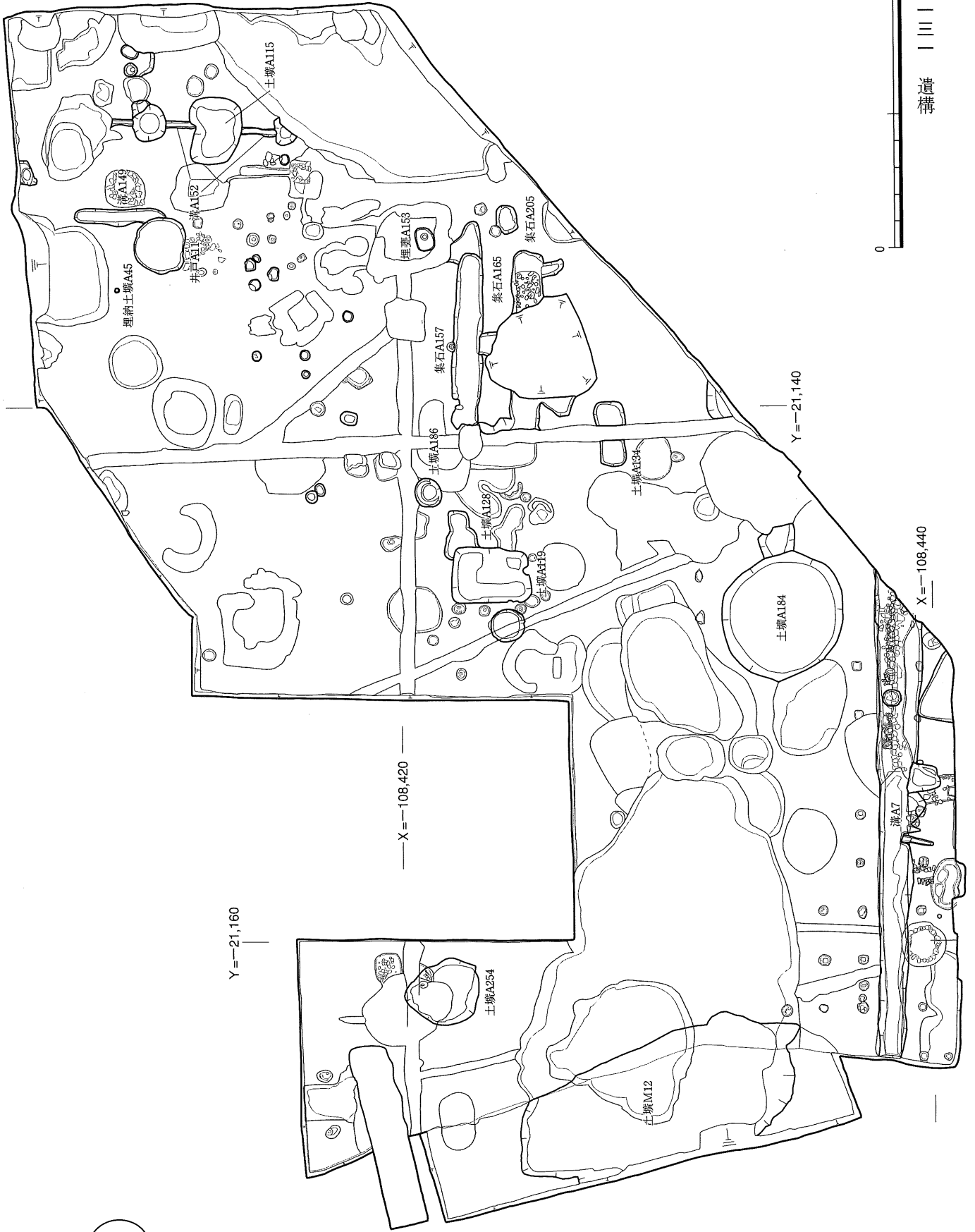
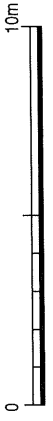

A・M区江戸時代中期遺構平面図

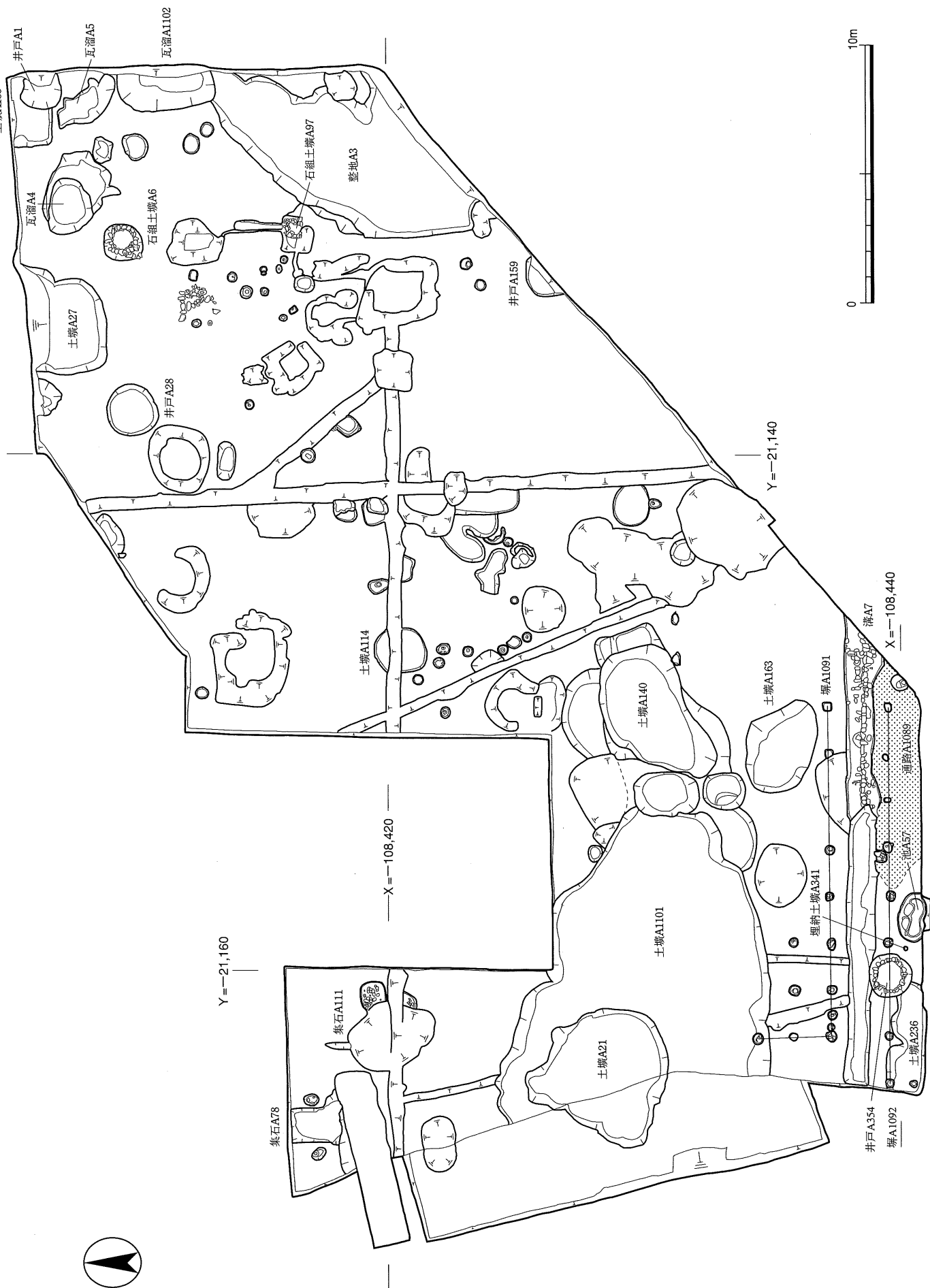

A・M区江戸時代後期遺構平面図

⊙ A区建物A1086

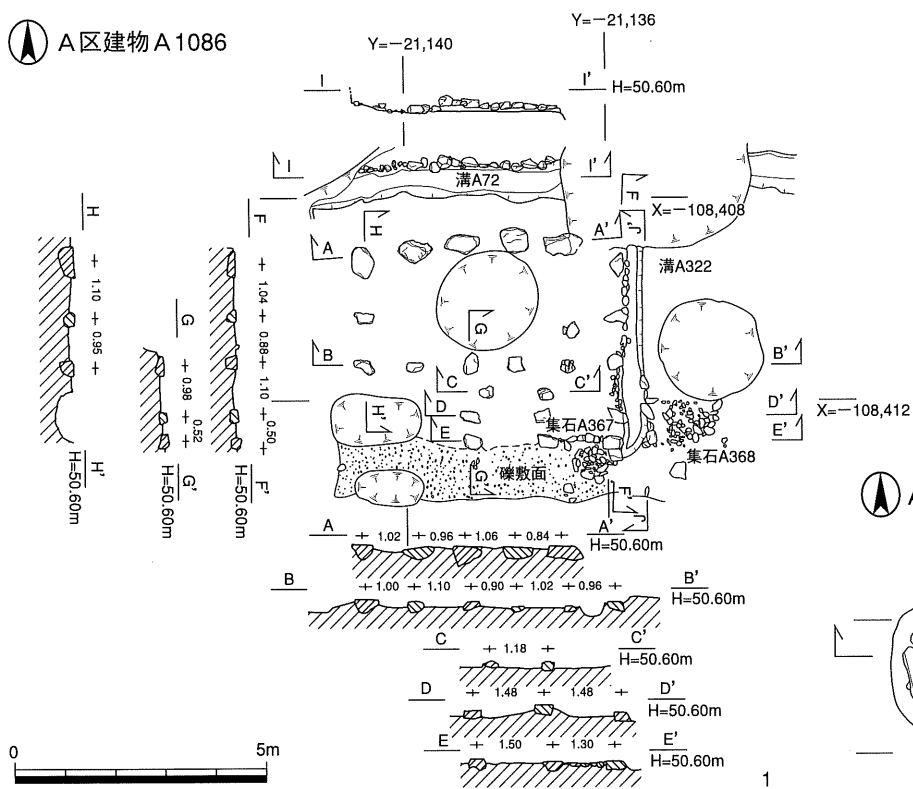

⊙ A区集石A367

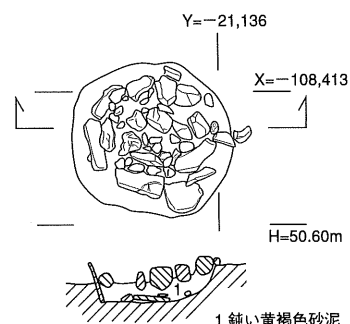

⊙ A区建物A1087

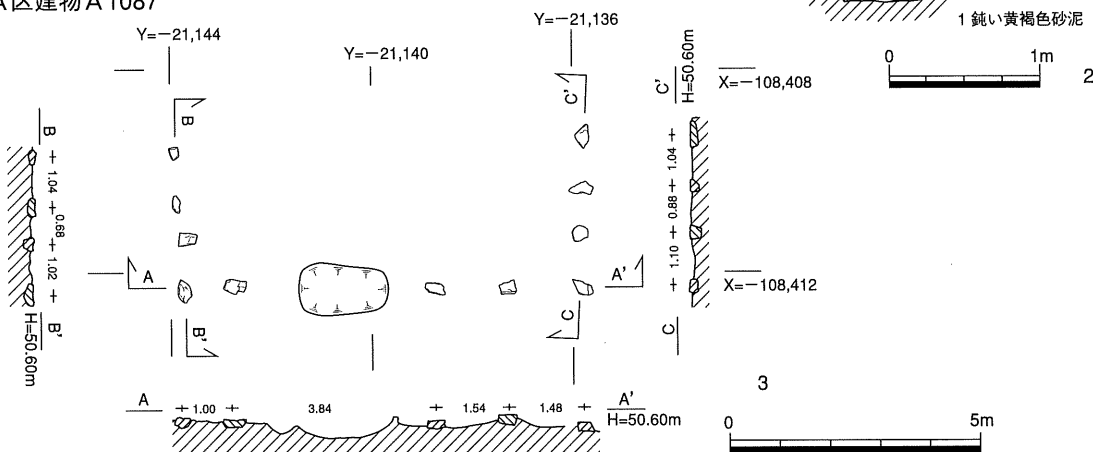

⊙ A区竈A329

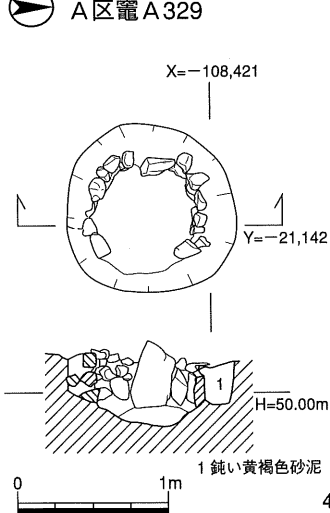

⊙ A区集石A157・A165・A205

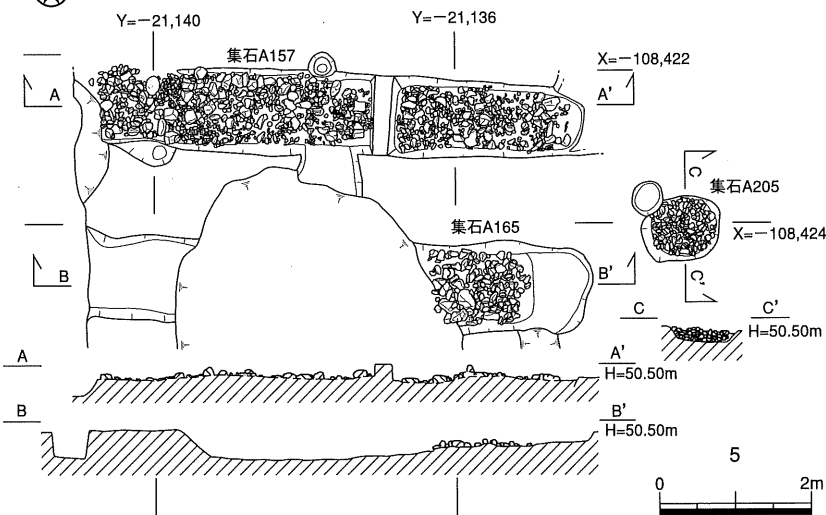

1 A区建物A1086実測図

2 A区集石A367実測図

3 A区建物A1087実測図

4 A区竈A329実測図

5 A区集石A157・A165・A205実測図



⊙ A区建物A1088

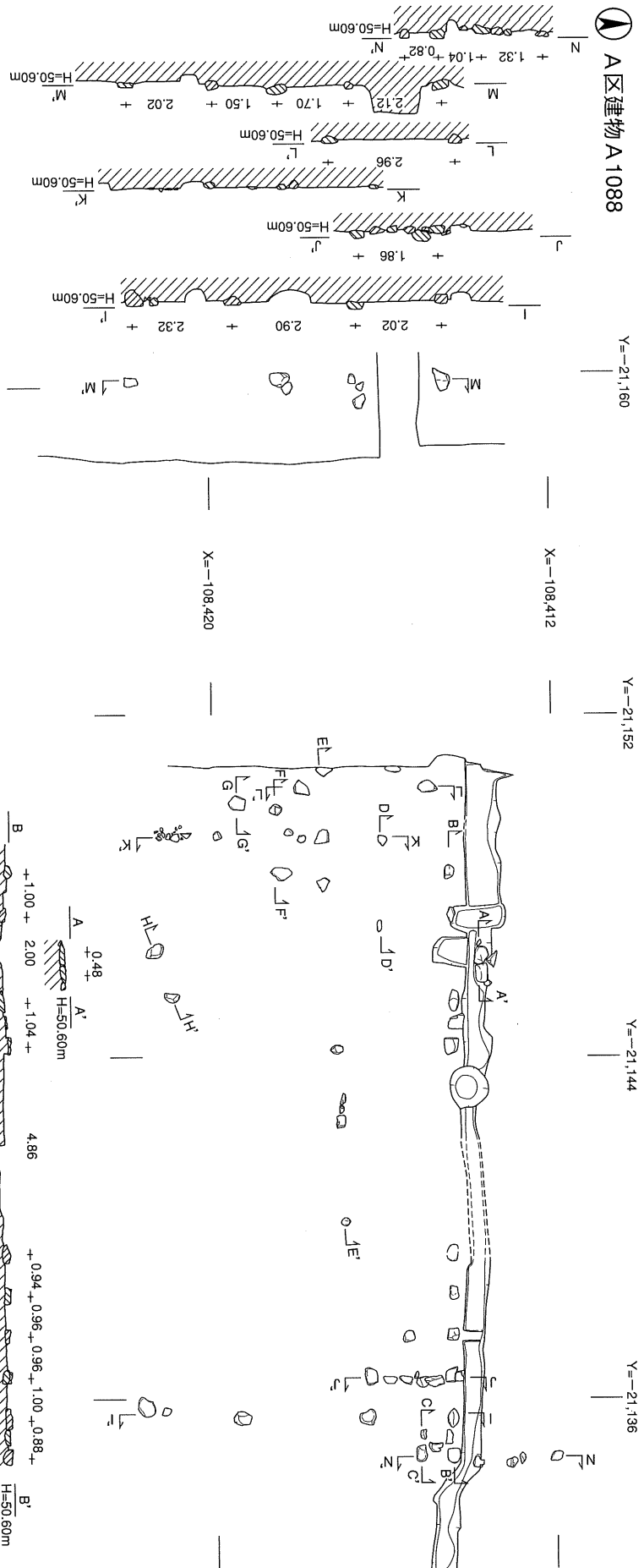

Y=-21,160

X=-108,412

Y=-21,152

Y=-21,144

Y=-21,136

X=-108,420

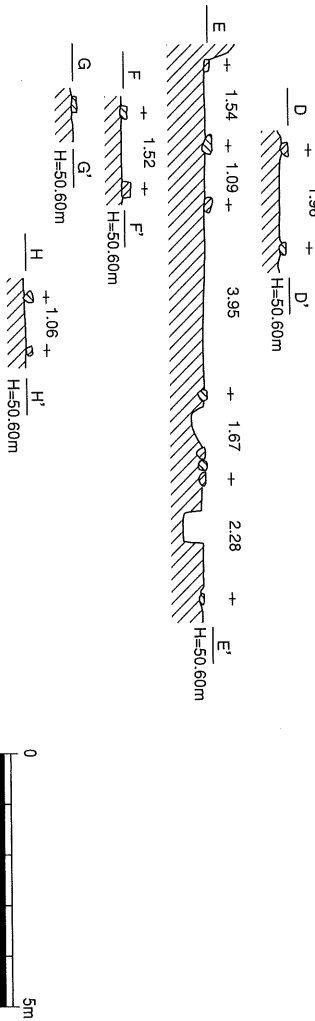

A区建物A1088実測図

▲ A区溝A7 (第1面)

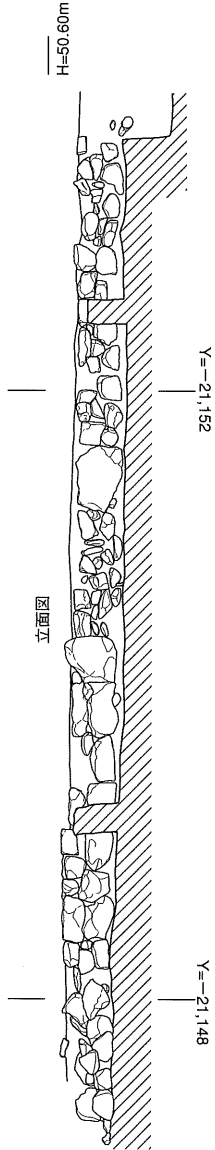

▲ A区溝A7 (第2面)

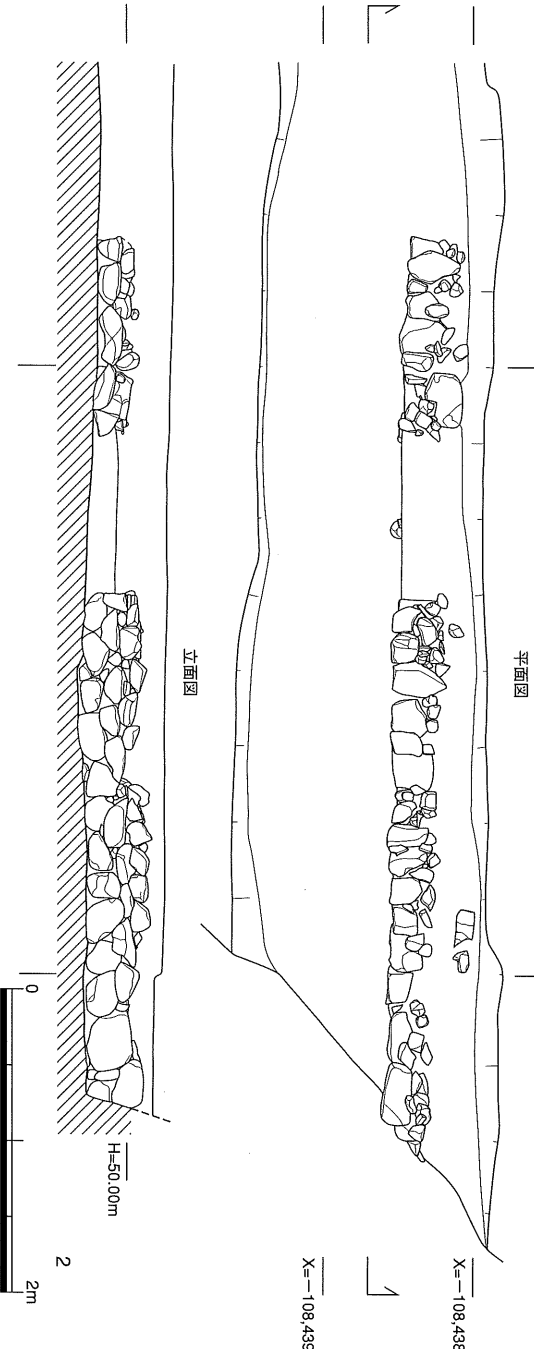
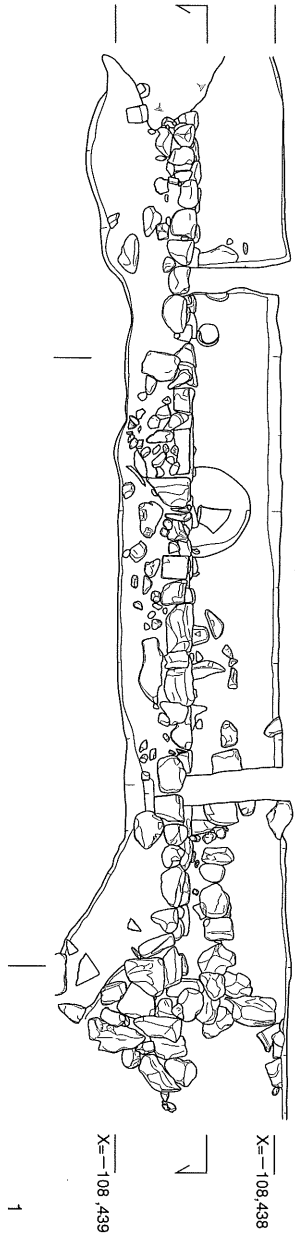

▲ A区池A57

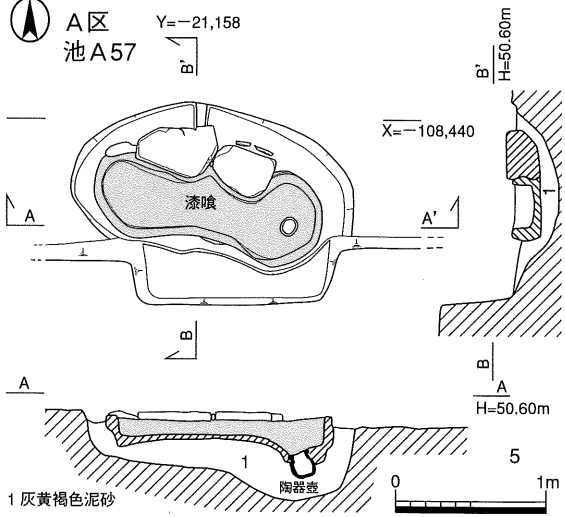

▲ A区埋納土壙A341

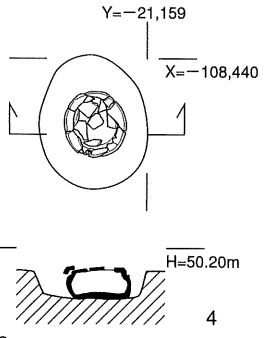

▲ A区埋納土壙A45

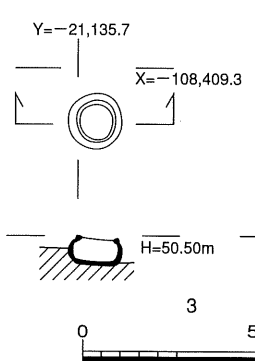

1 A区溝A7 (第1面) 実測図    2 A区溝A7 (第2面) 実測図    3 A区埋納土壙A45実測図  
4 A区埋納土壙A341実測図    5 A区池A57実測図

⊙ A区石組土塙A6

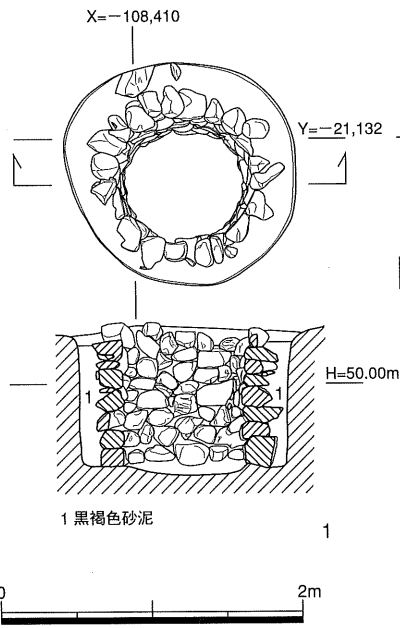

⊙ A区石組土塙A97

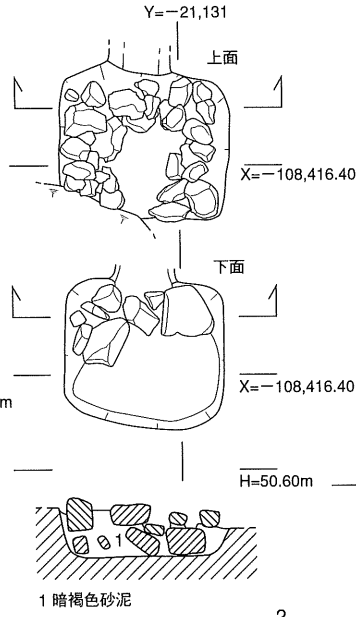

⊙ A区井戸A354 Y=-21,160

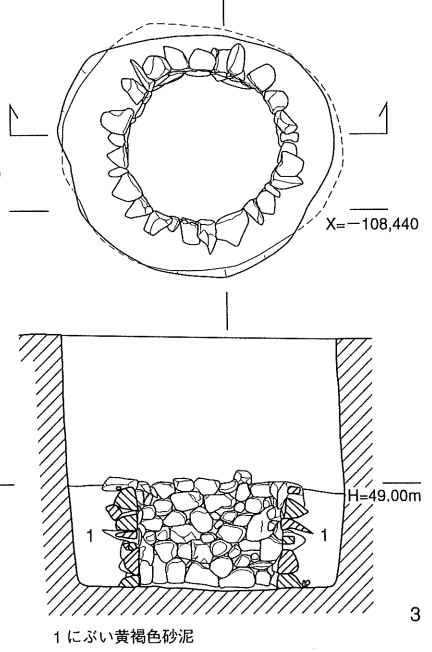

⊙ B区建物B1094

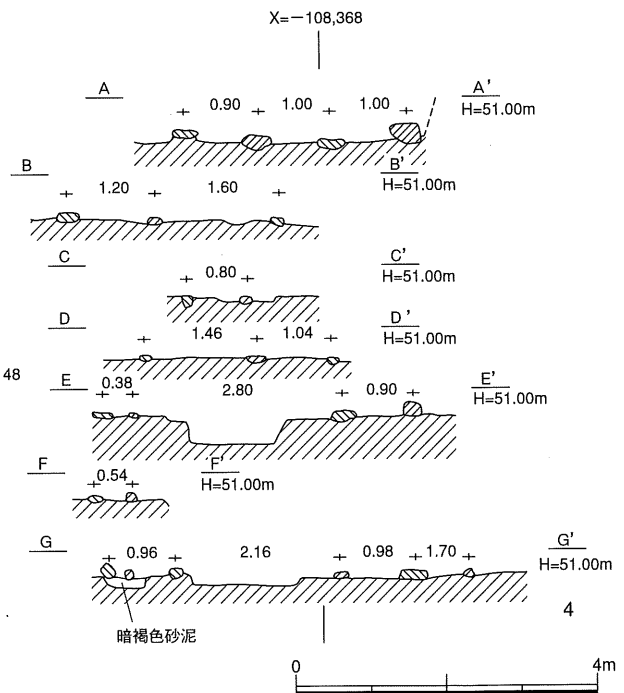
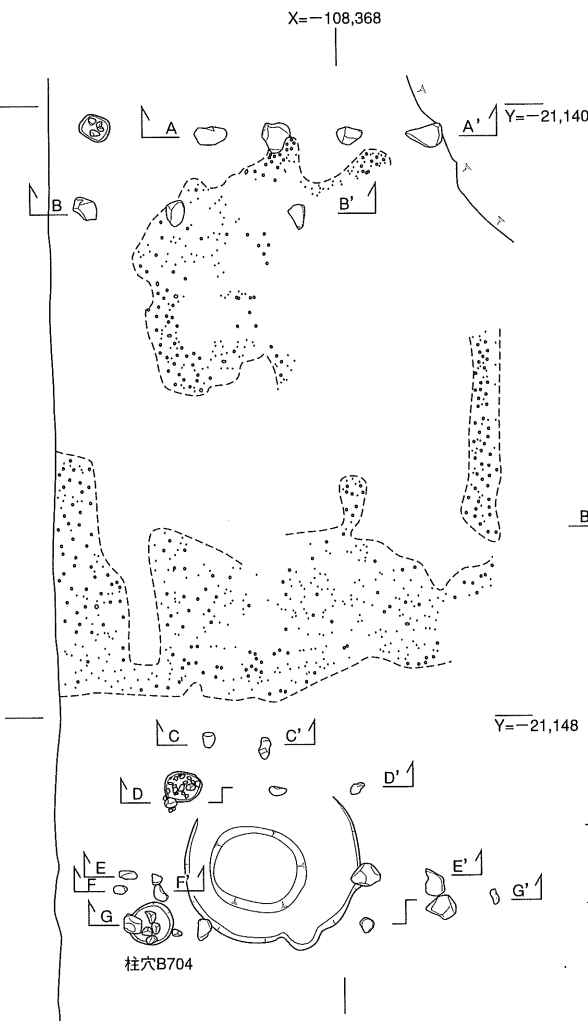

1 A区石組土塙A6実測図  
4 B区建物B1094実測図

2 A区石組土塙A97実測図

3 A区井戸A354実測図

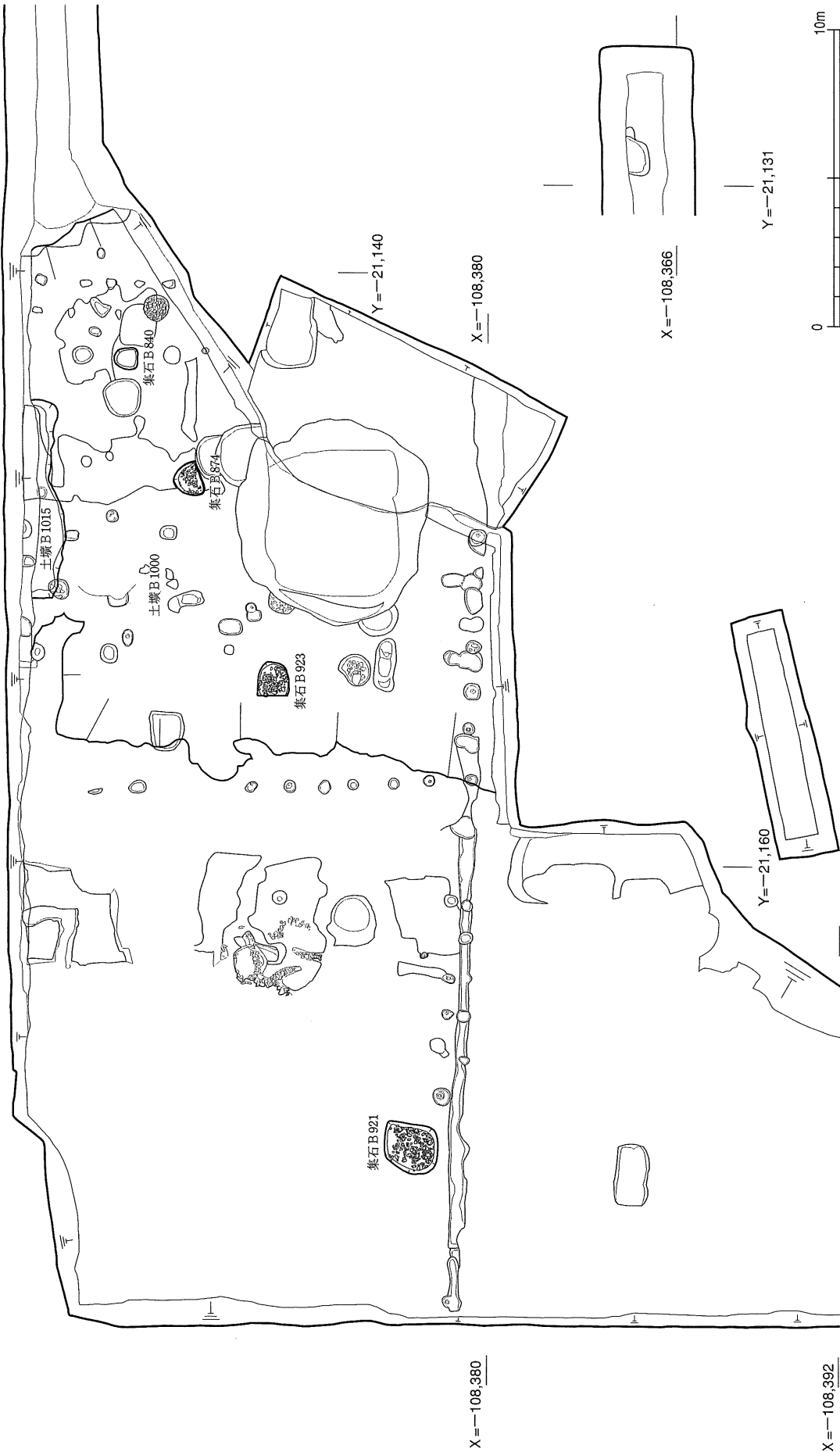

B区北部・N区桃山期遺構平面図



桃山時代

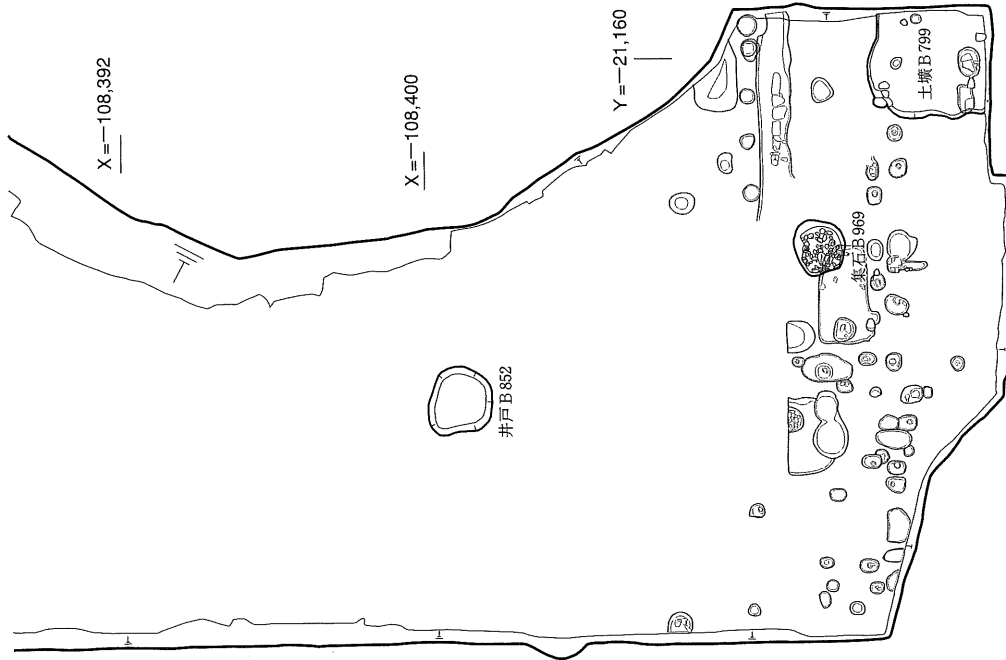

江戸時代前期

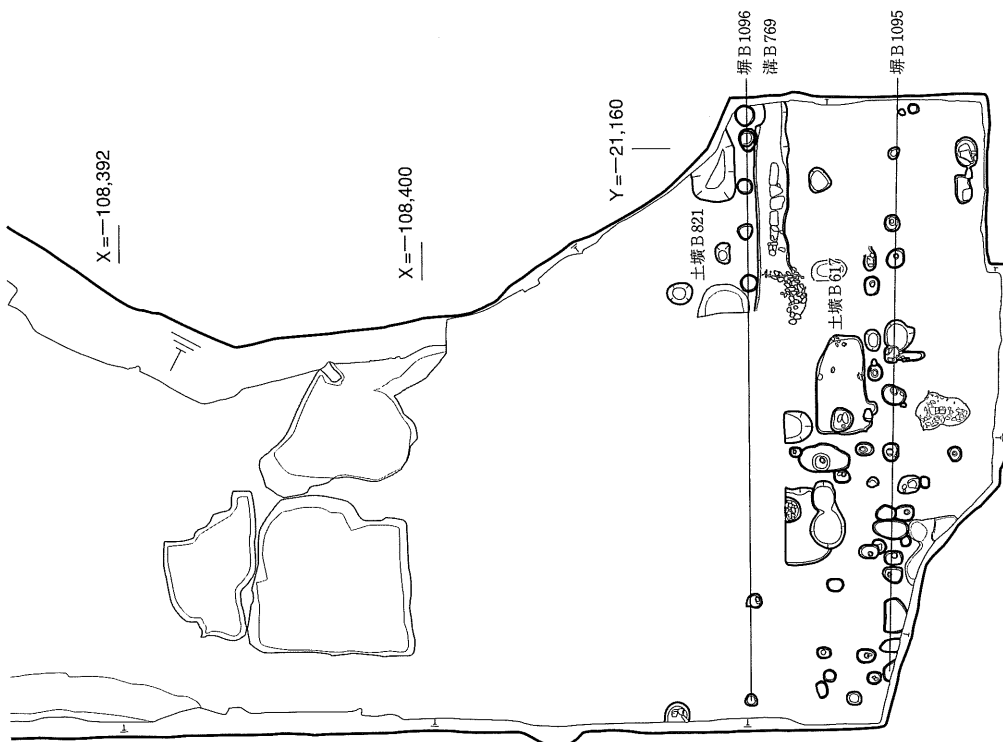

図版一三九 遺構

B区南部桃山期・江戸時代前期遺構平面図

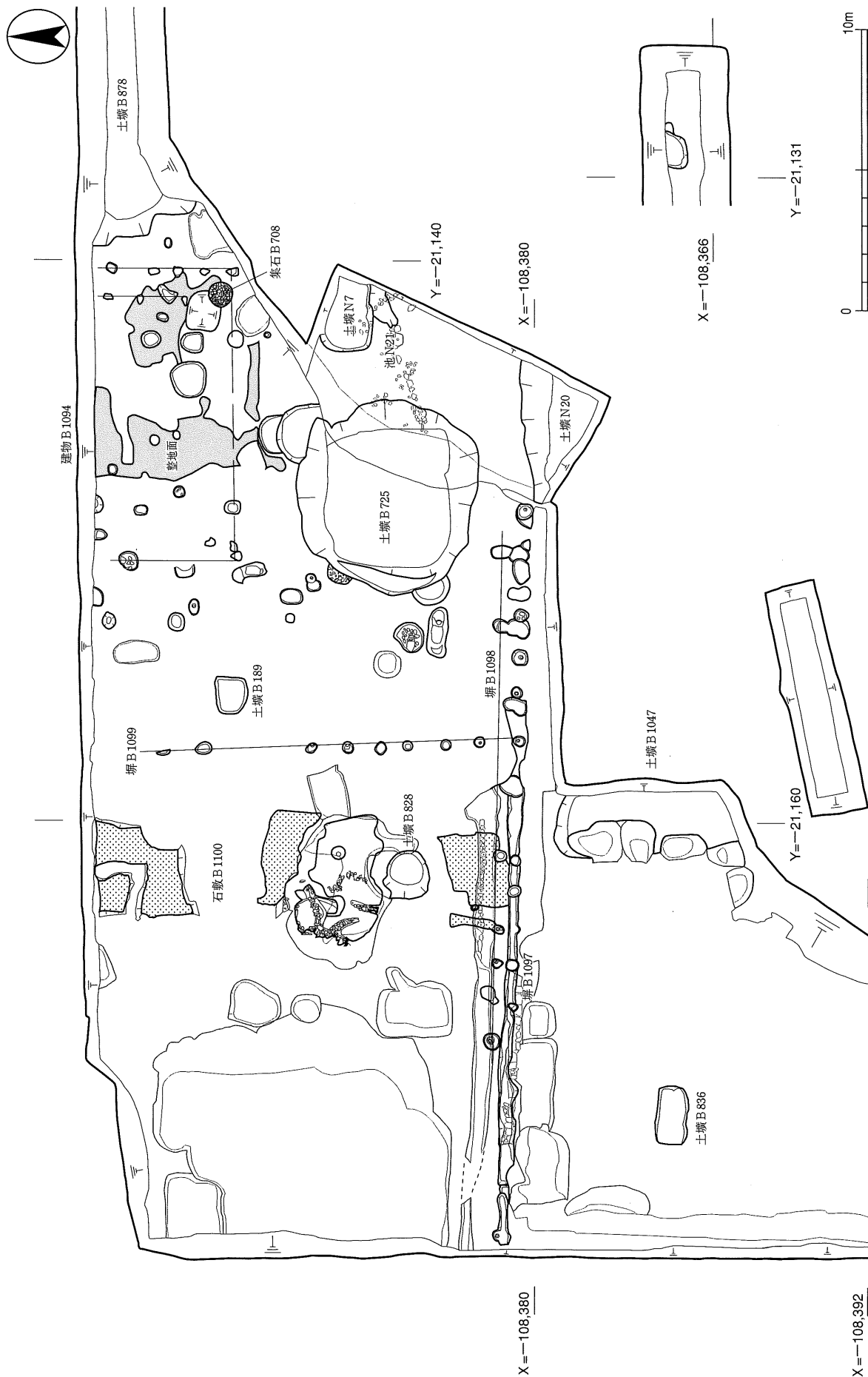

B区北部・N区江戸時代前期遺構平面図

B区北部・N区江戸時代中期遺構平面図

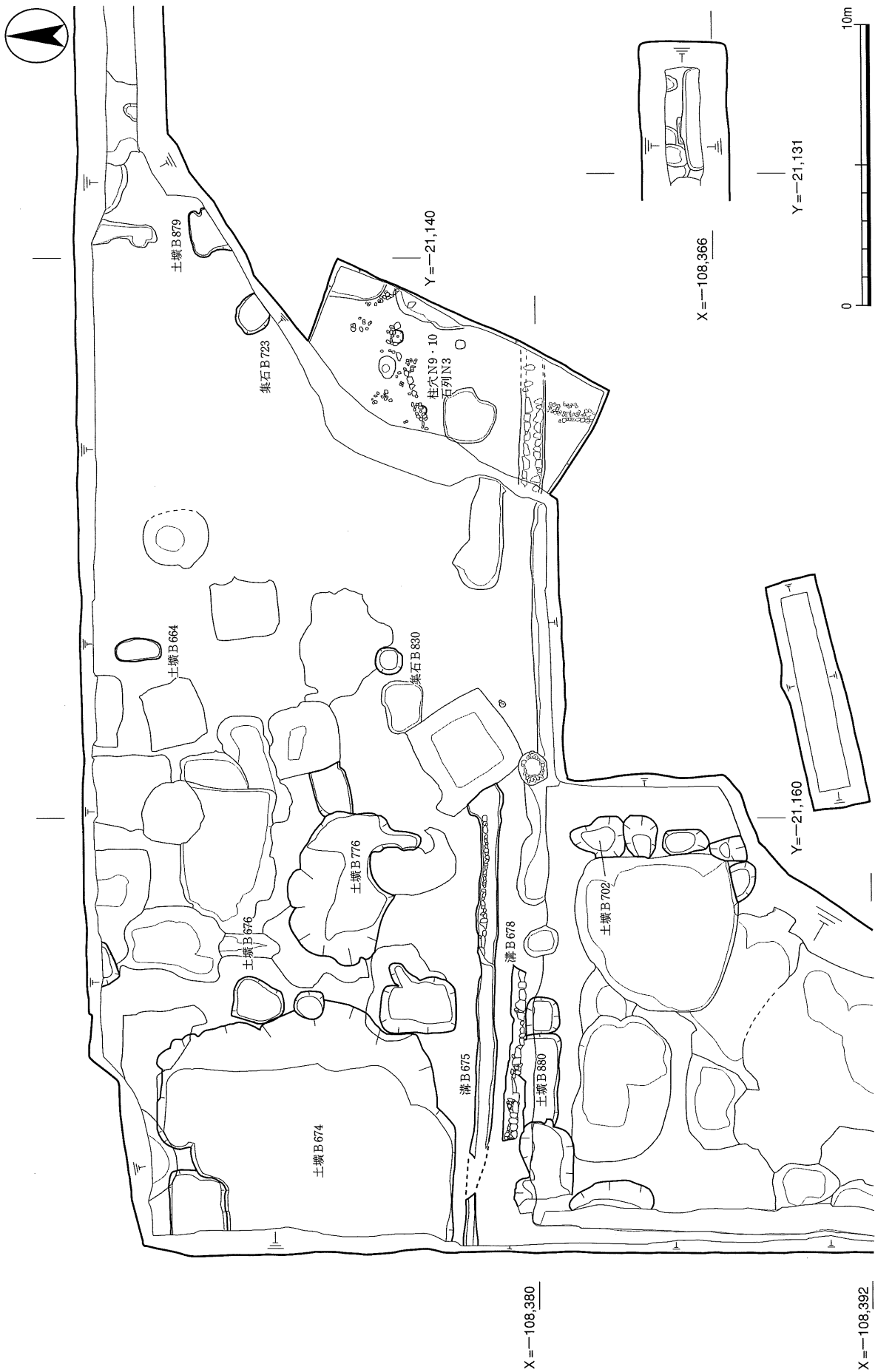



江戸時代中期

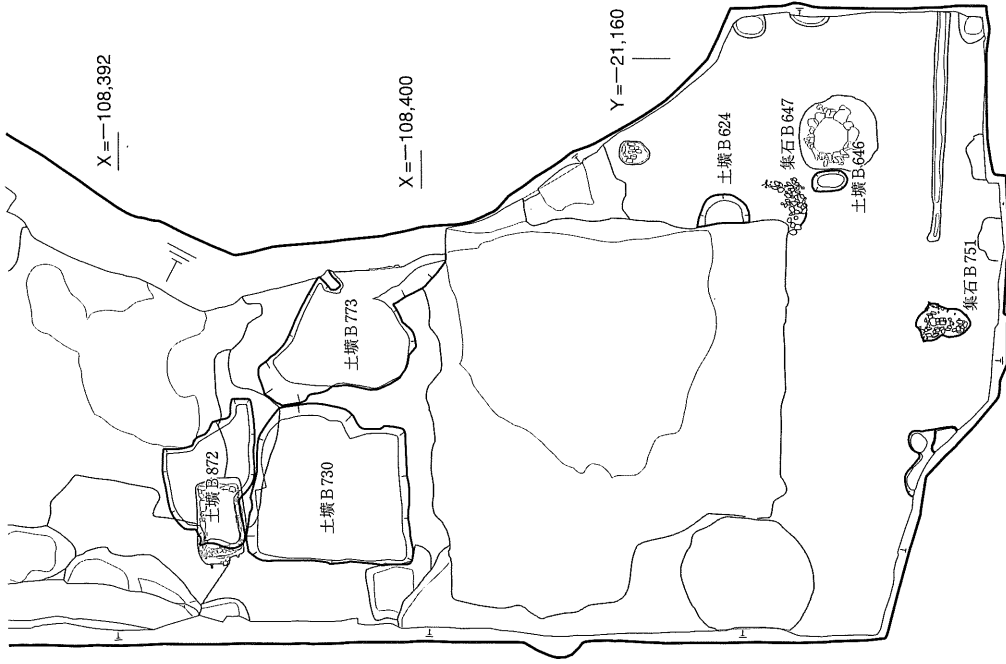

江戸時代後期

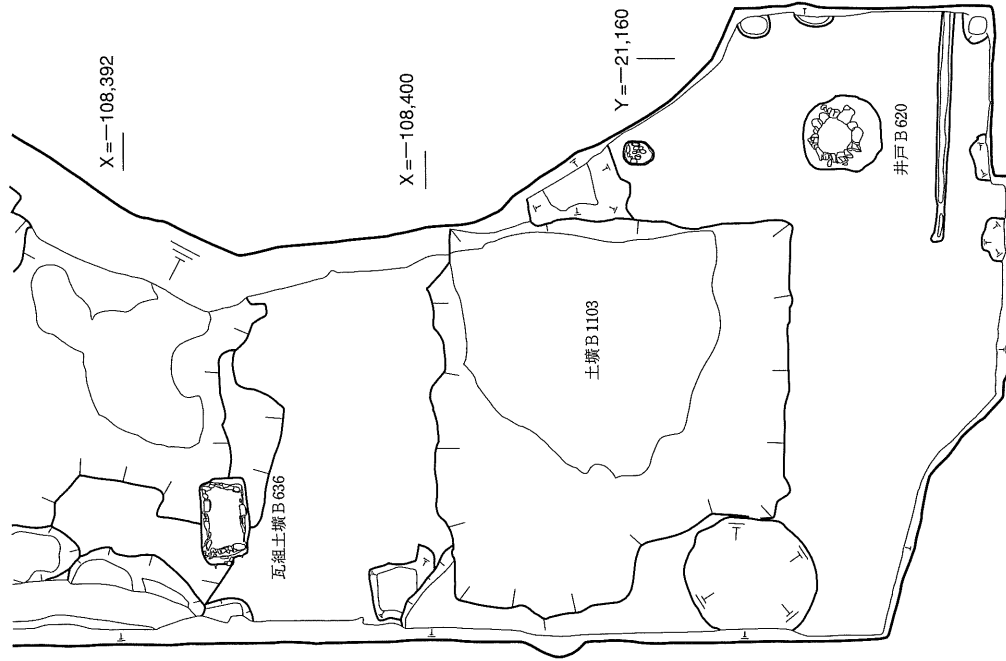

B区南部江戸時代中期・後期遺構平面図

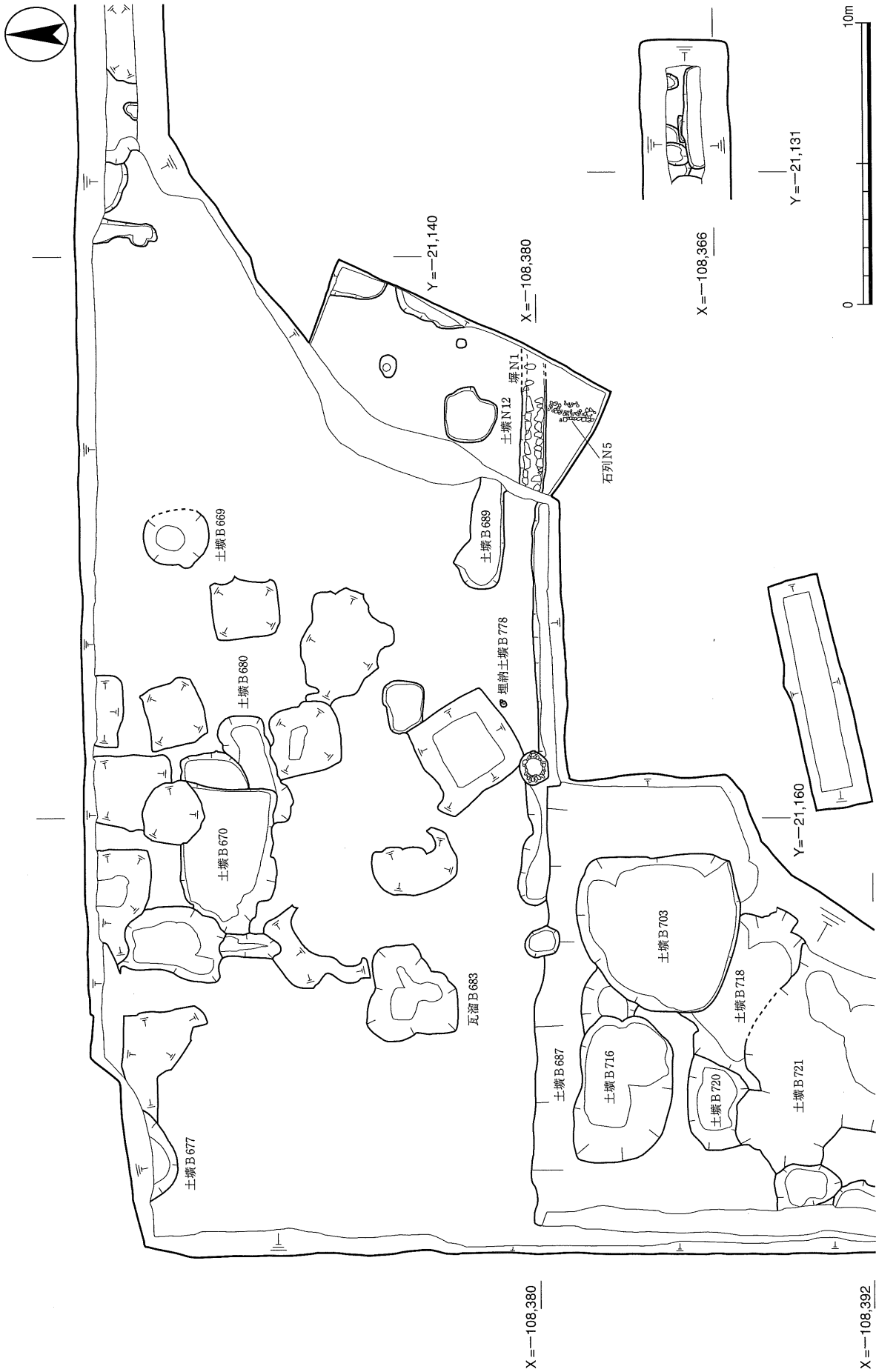

図版一四三 遺構

B区北部・N区江戸時代後期遺構平面図

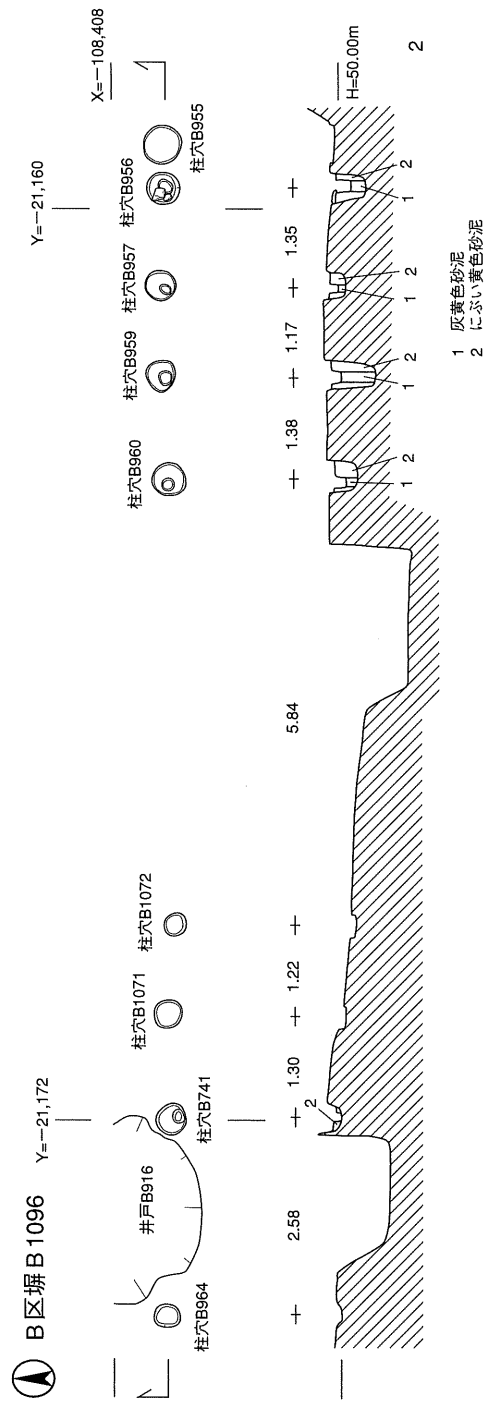
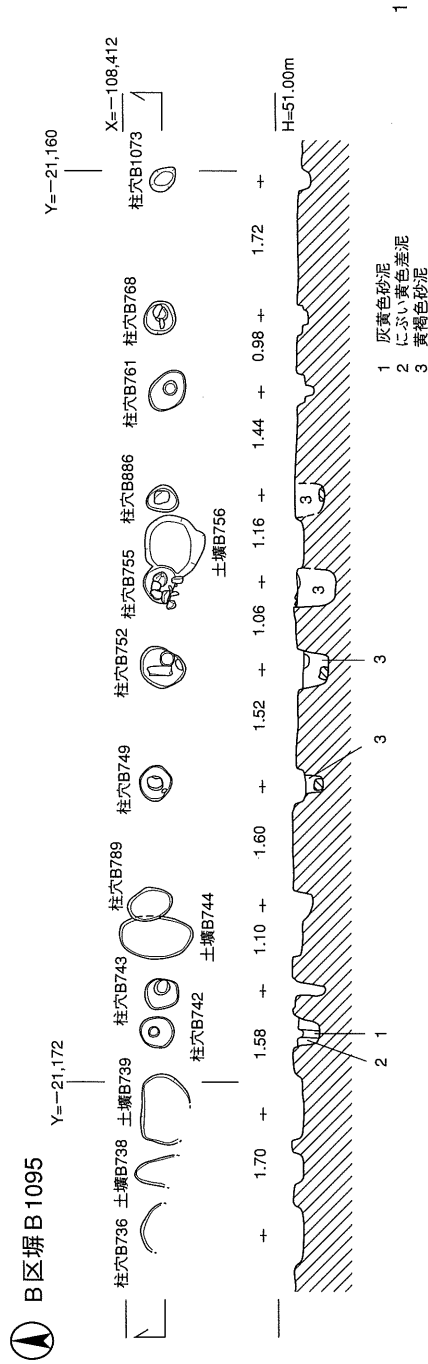

1 B区堀B 1095実測図

2 B区堀B 1096実測図

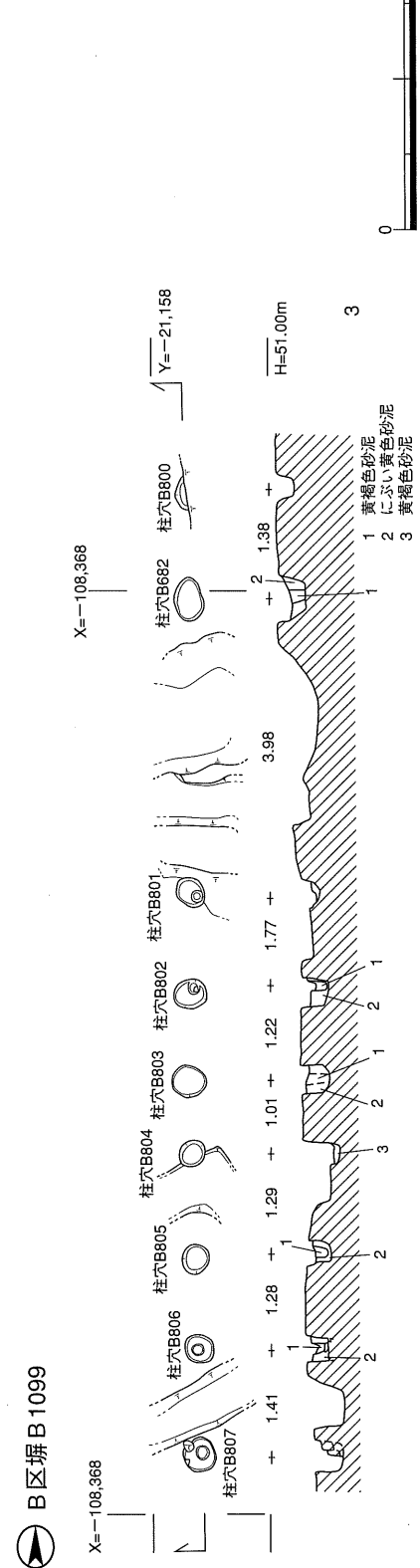
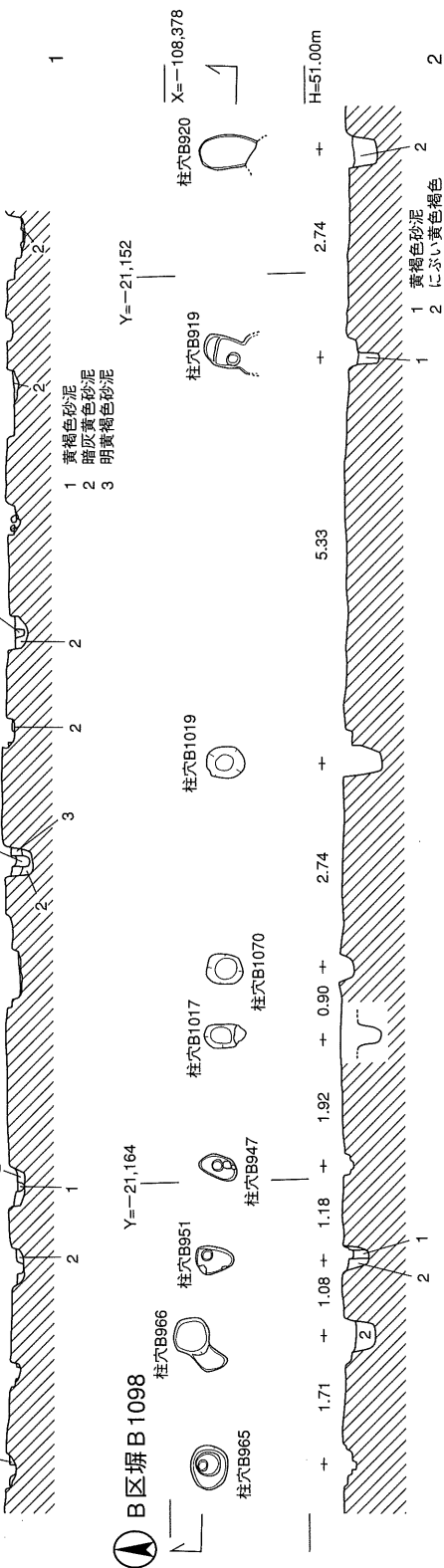
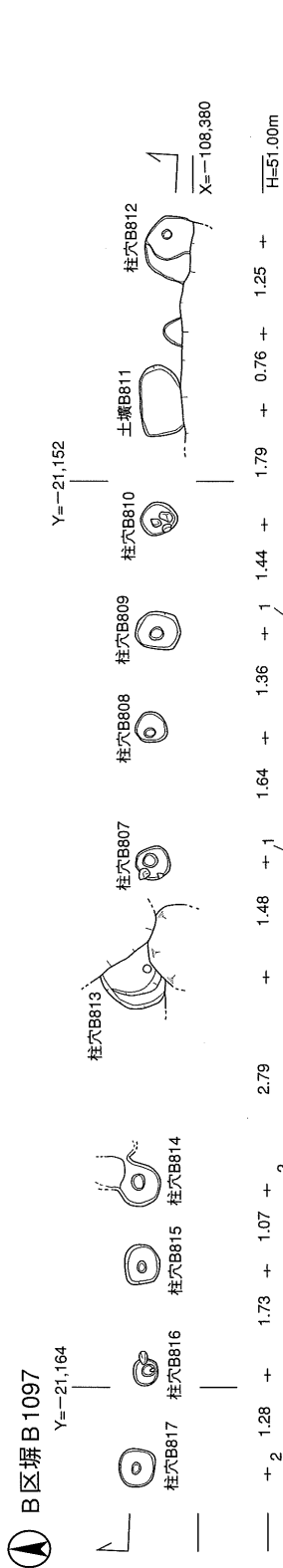

1 B区堀 B1097実測図

2 B区堀 B1098実測図

3 B区堀 B1099実測図

● B区土壤 B725

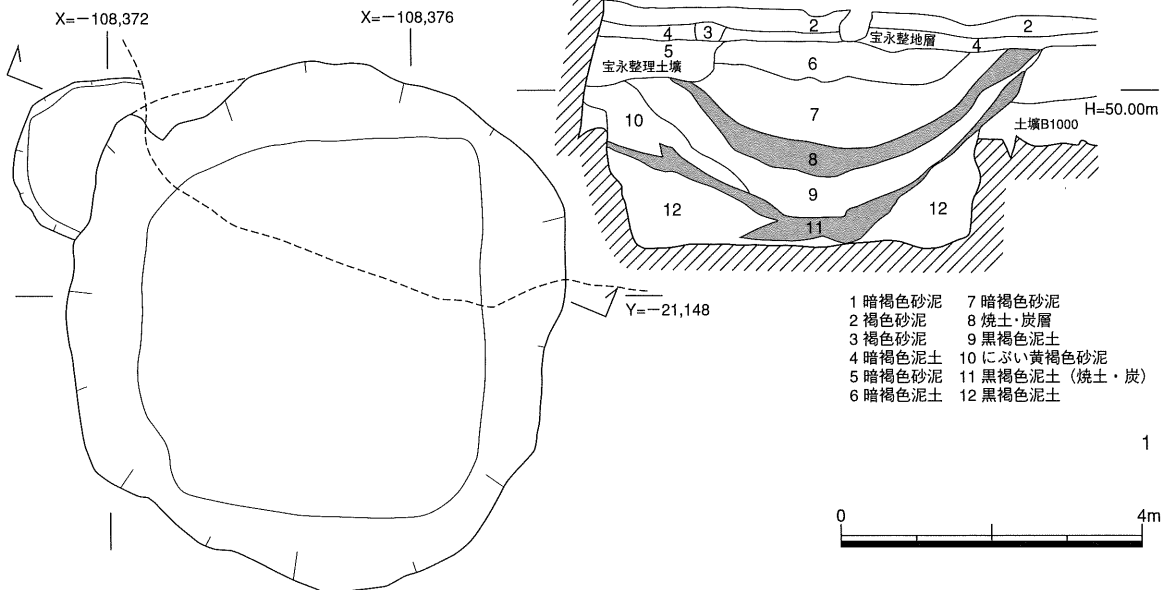

▲ B区溝 B675

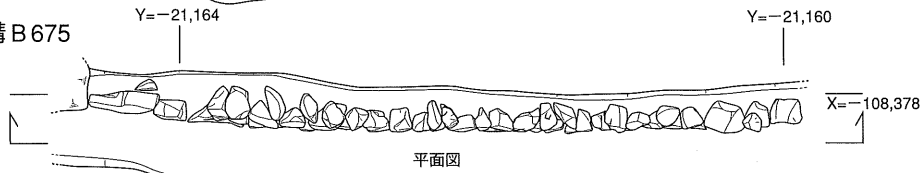

▲ B区溝 B678

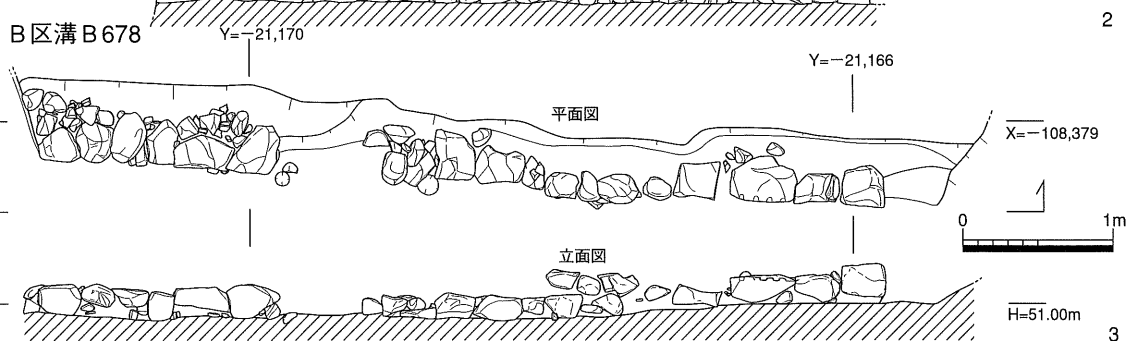

▲ B区瓦組土壤 B636

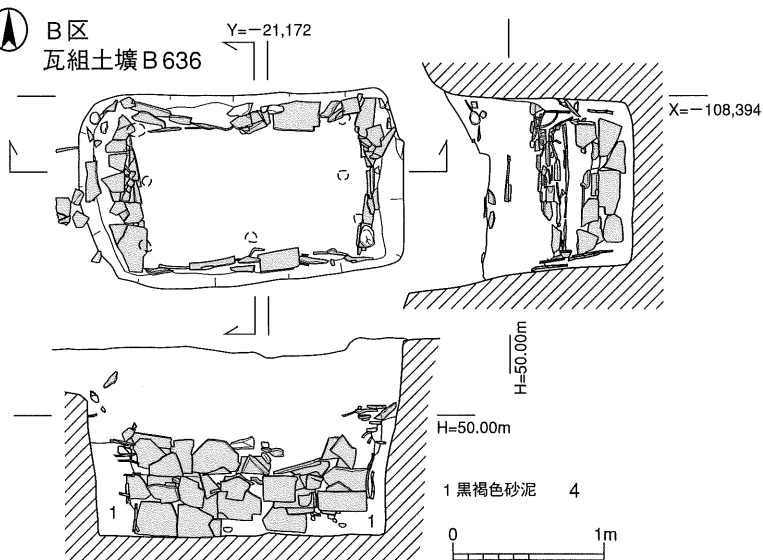

● B区埋納土壤 B778

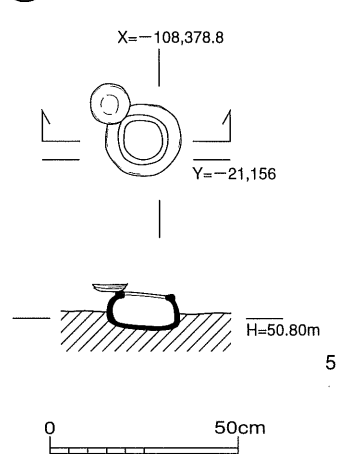

1 B区土壤 B725実測図 2 B区溝 B675実測図 3 B区溝 B678実測図  
4 B区瓦組土壤 B636実測図 5 B区埋納土壤 B778実測図



Y=-21,120

Y=-21,104

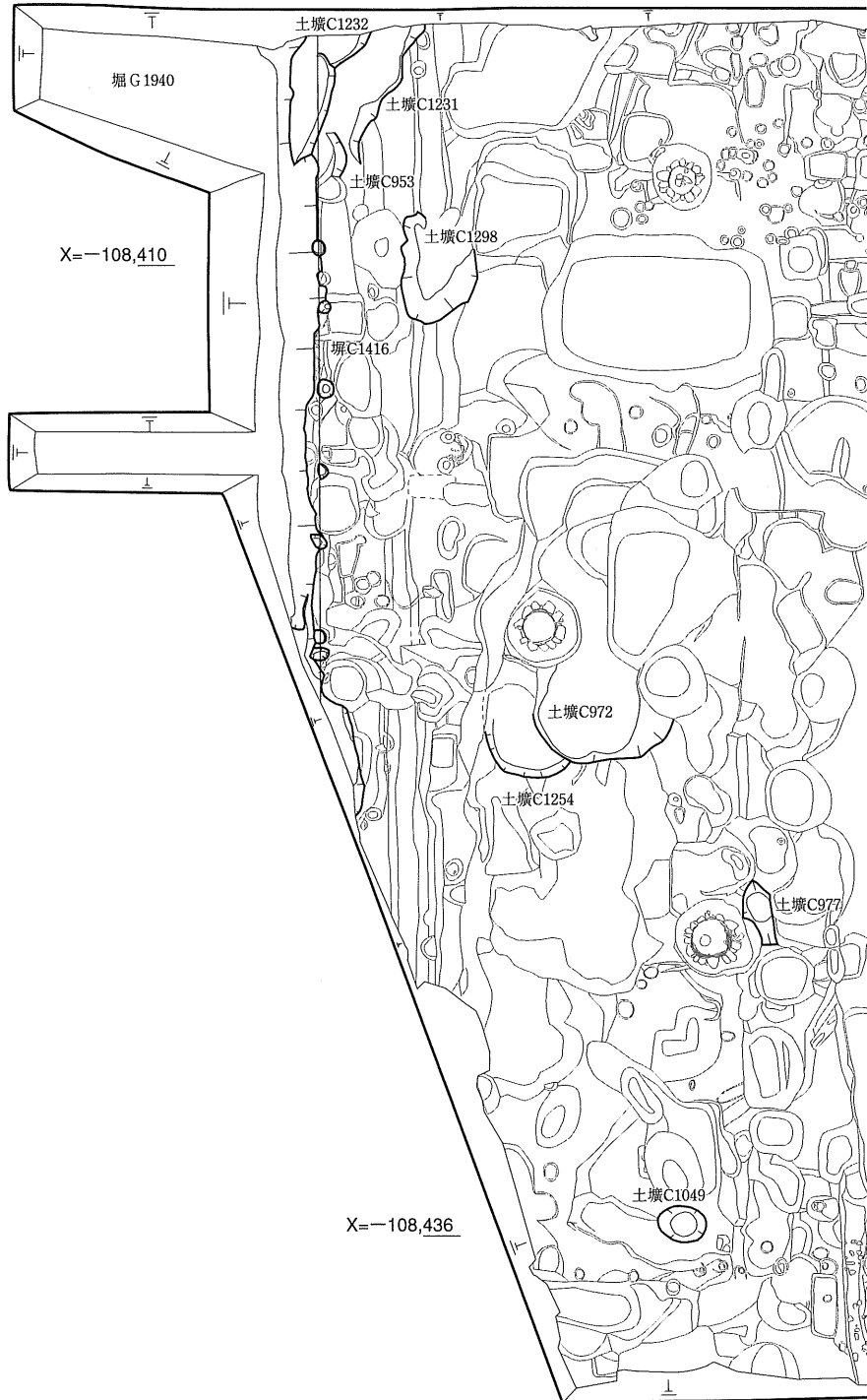

C区西部桃山期遺構平面図

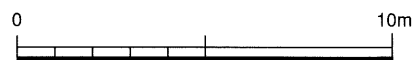
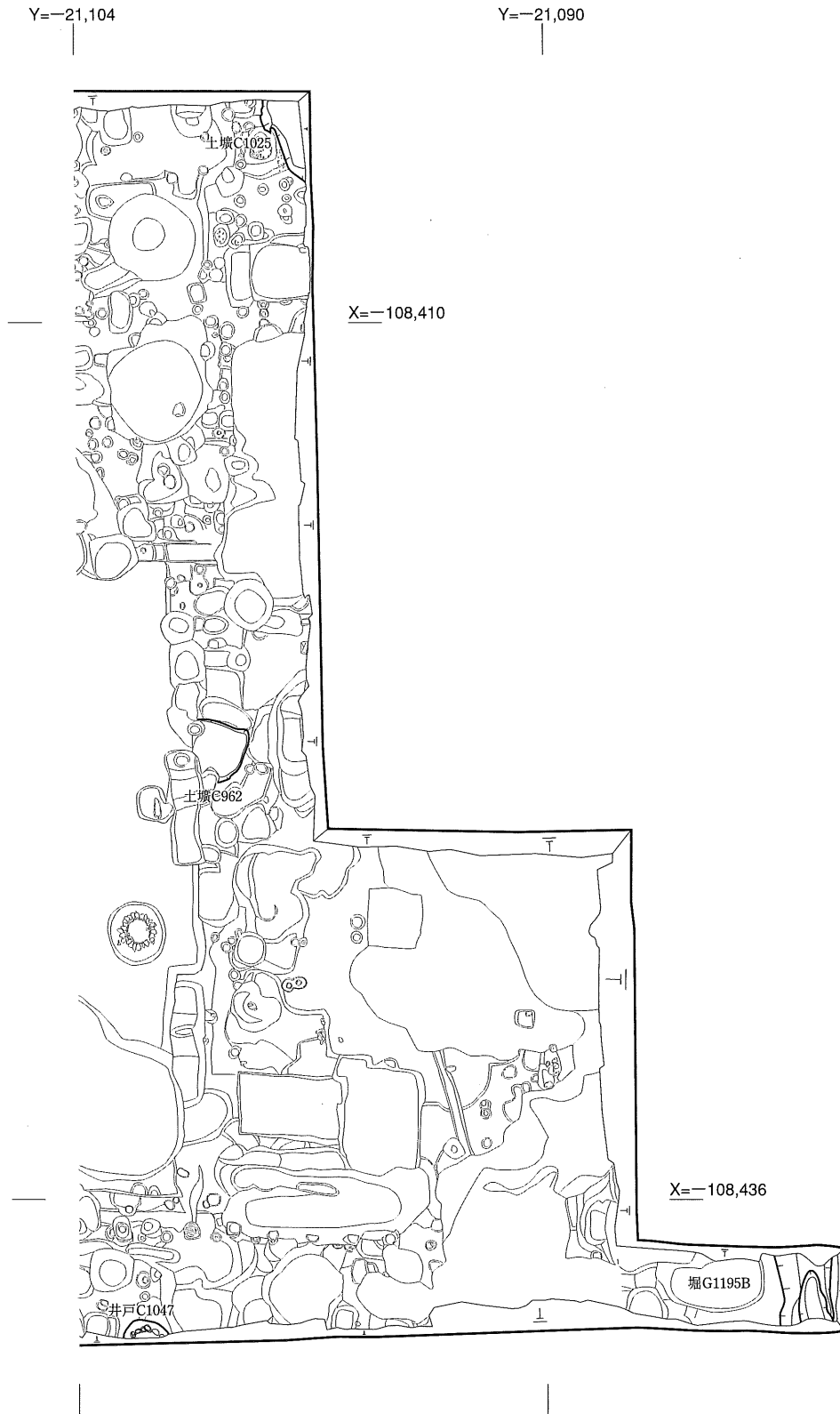

C区東部桃山期遺構平面図



Y=-21,120

Y=-21,104

X=-108,410

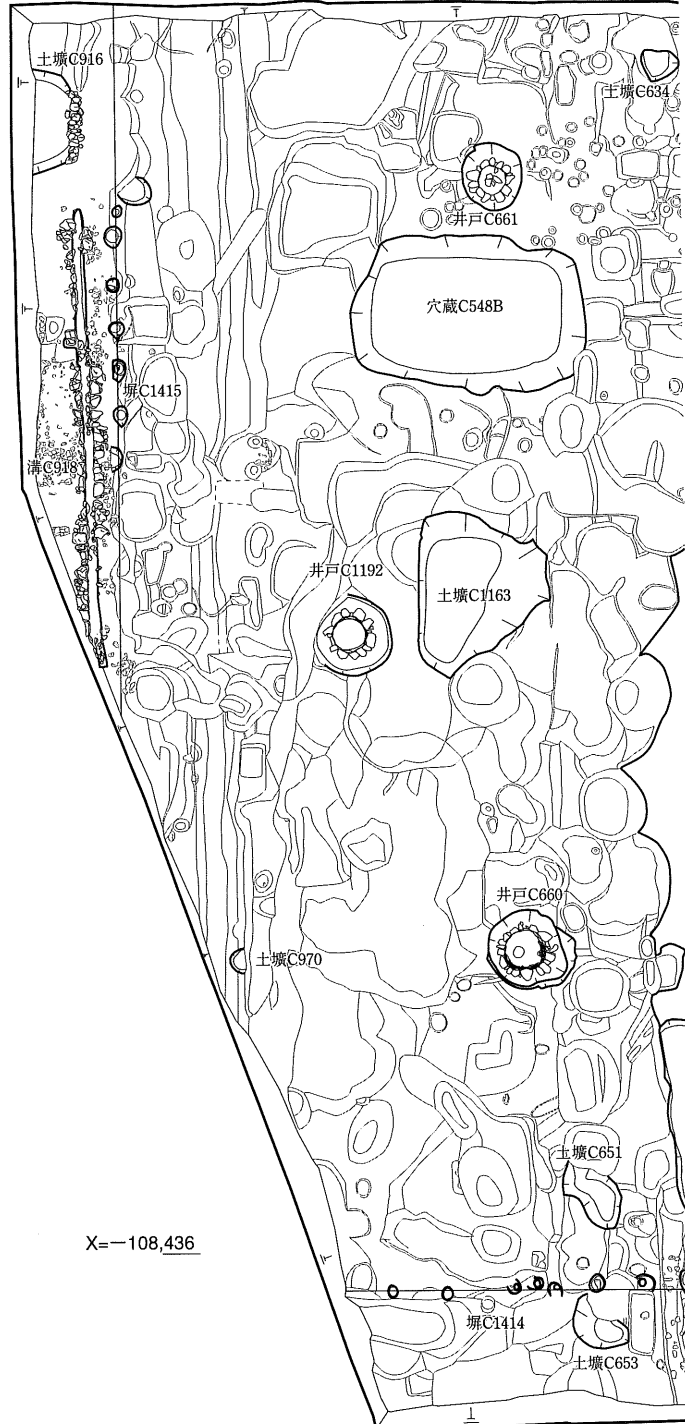

X=-108,436



C区西部江戸時代前期遺構平面図

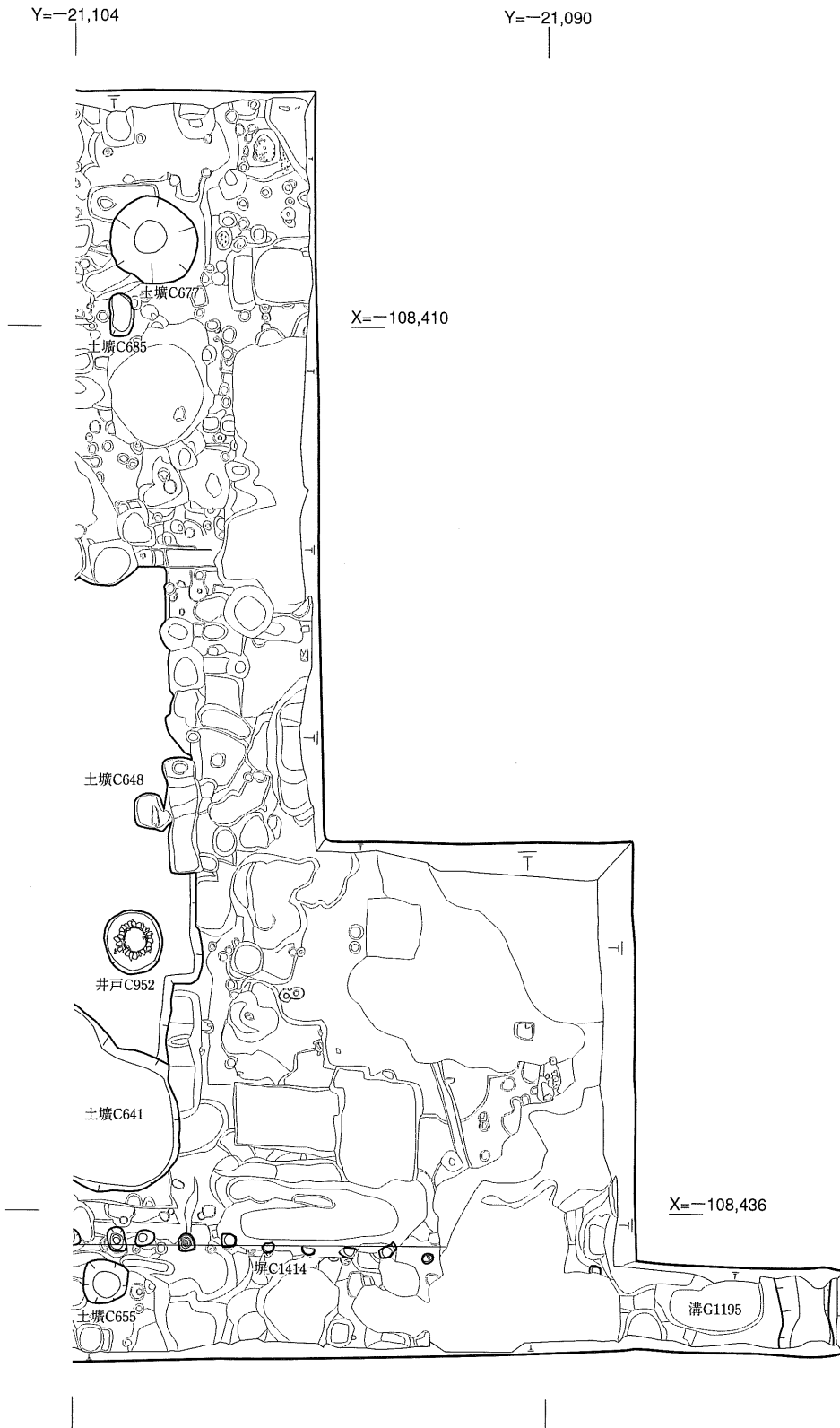

C区東部江戸時代前期遺構平面図



Y=-21,120

Y=-21,104

X=-108,410

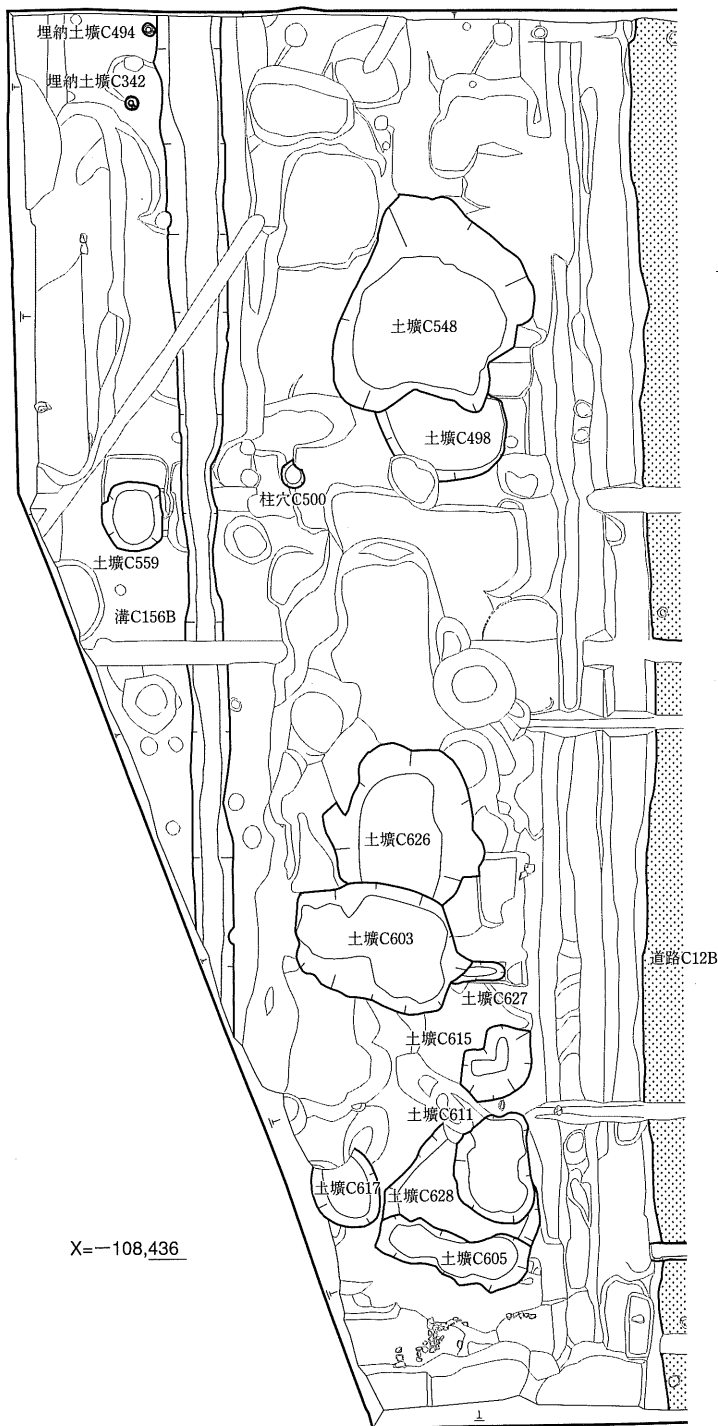

X=-108,436



C区西部江戸時代中期遺構平面図



Y=-21,104

Y=-21,090

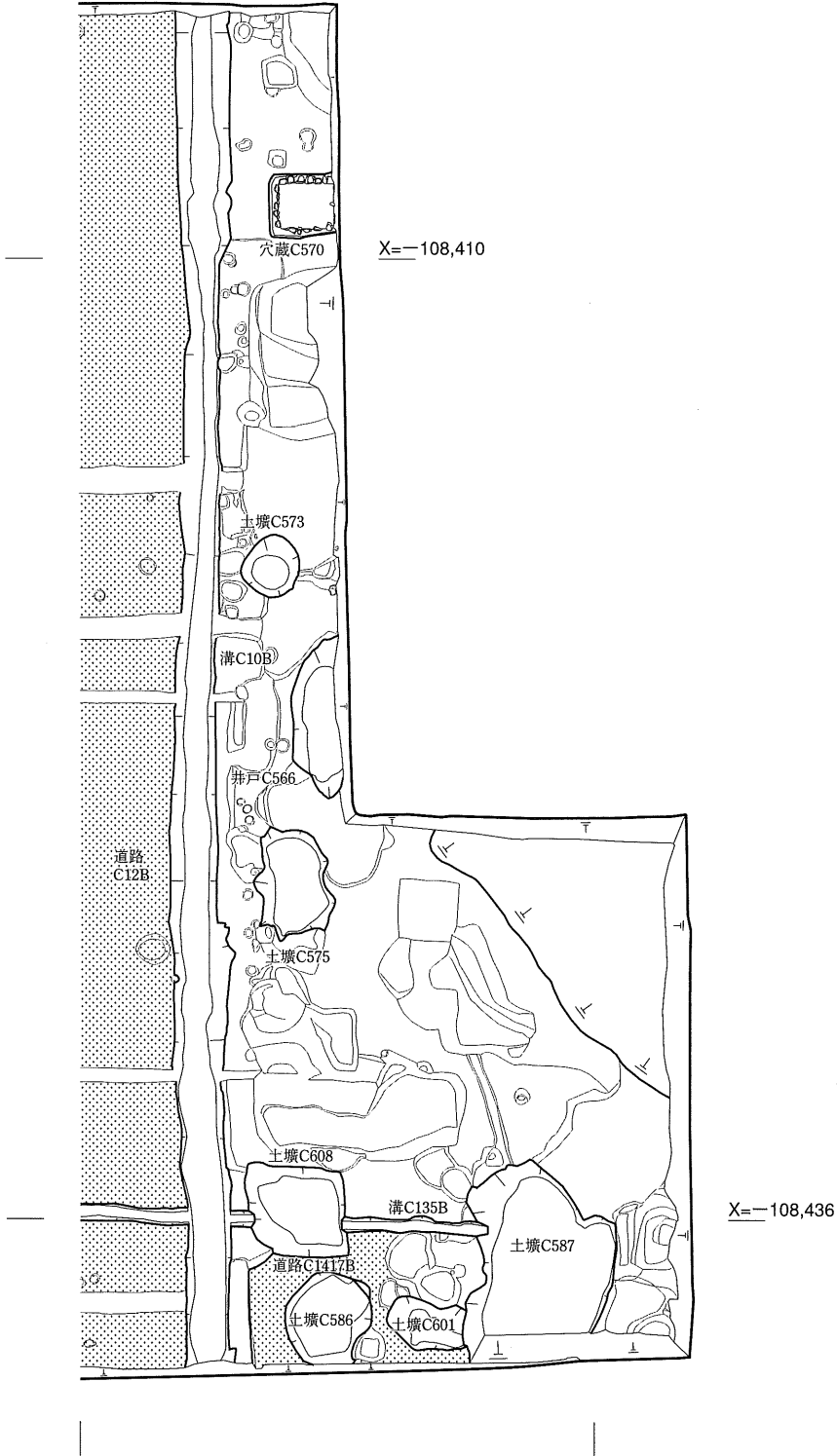

C区東部江戸時代中期遺構平面図

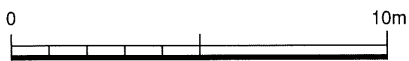
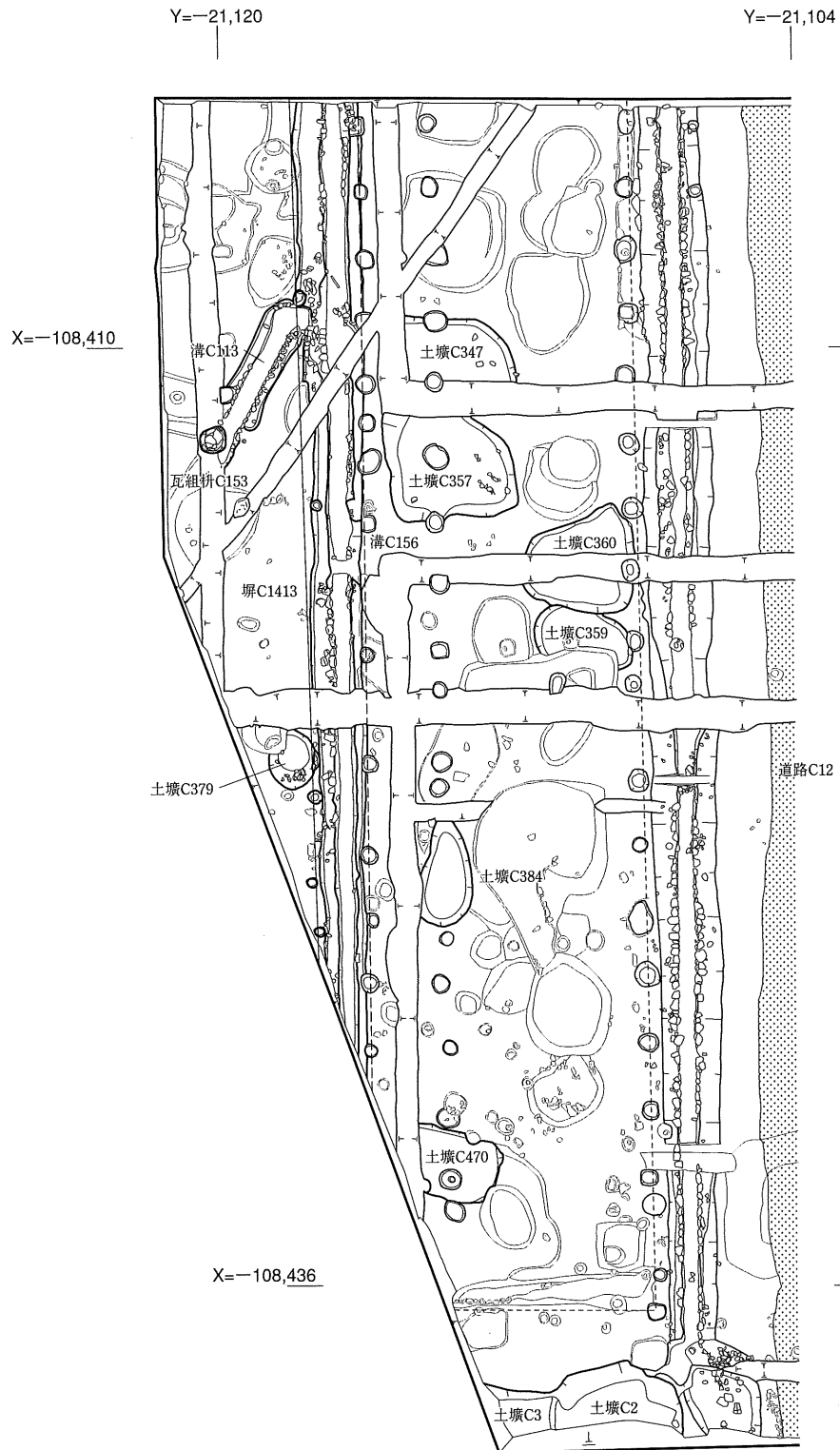

C区西部江戸時代後期遺構平面図

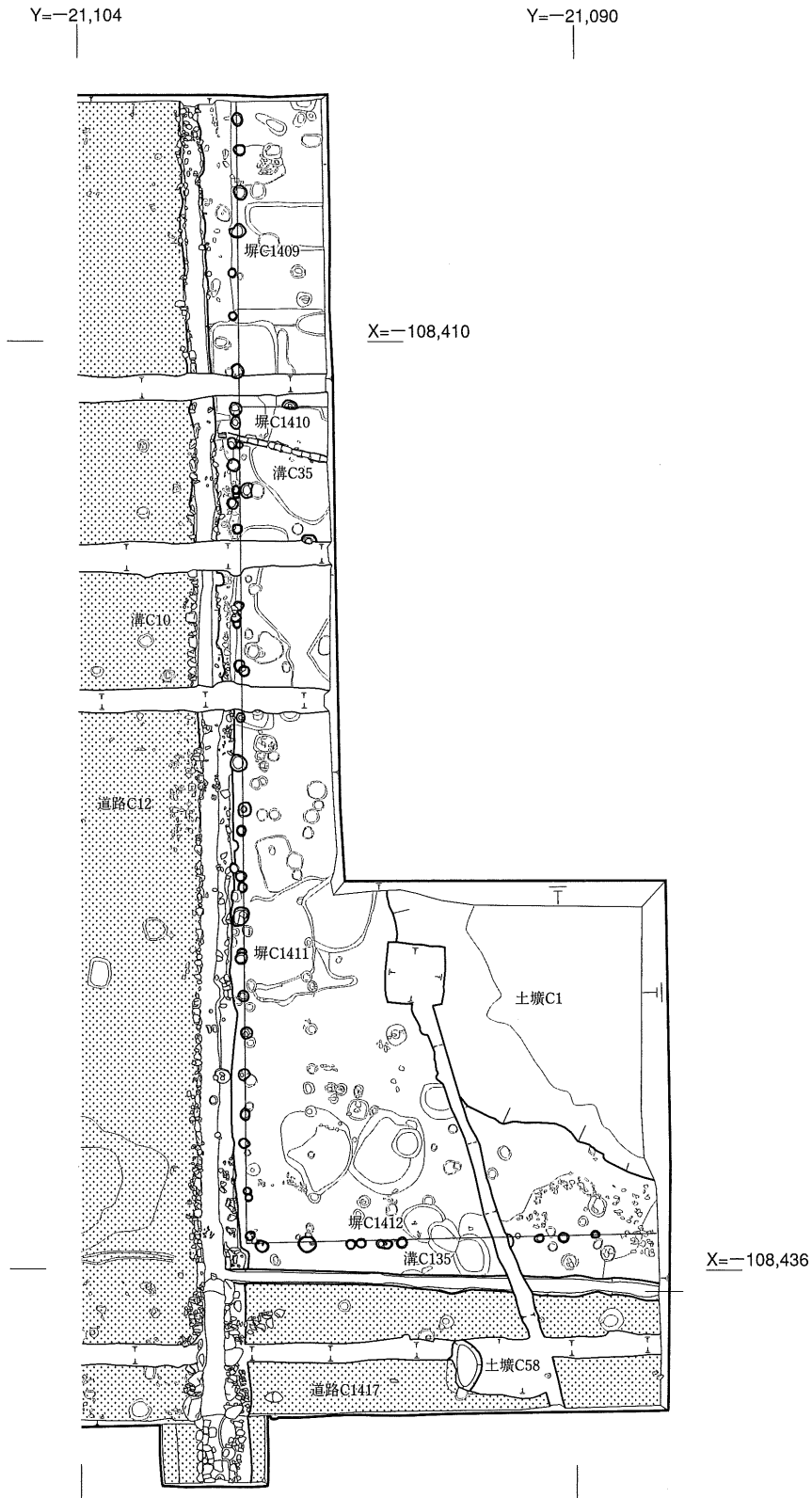

C区東部江戸時代後期遺構平面図

1 C区塀C1416実測図

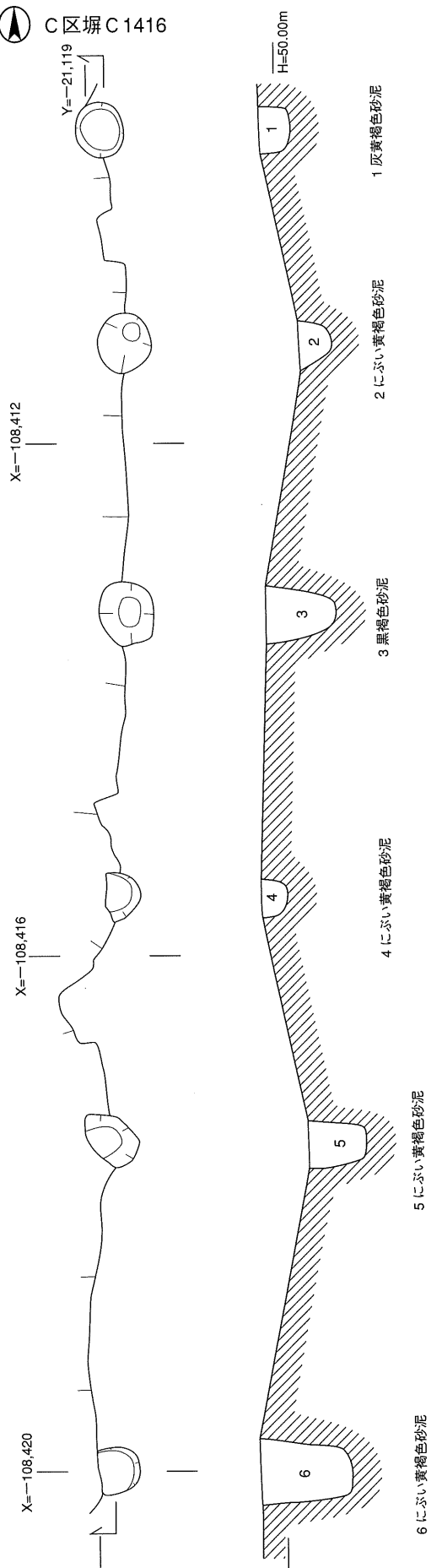

1 C区塀C1416実測図

2 C区塀C1415実測図

2 C区塀C1415実測図

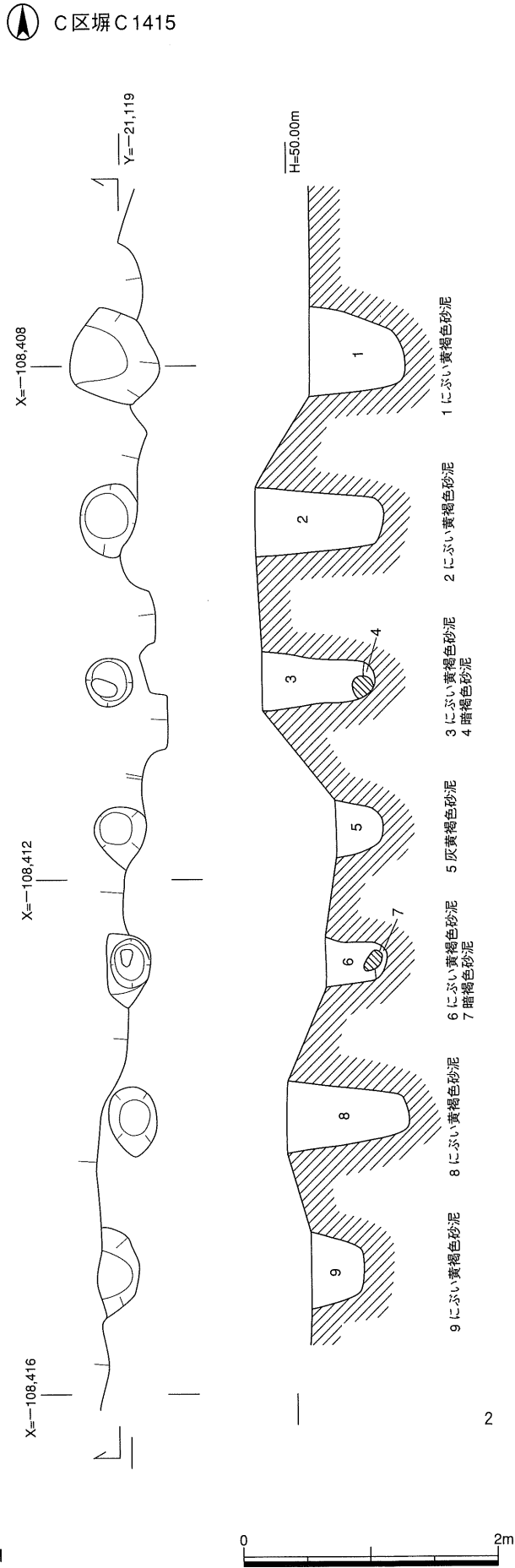

1 C区塀C1416実測図

2 C区塀C1415実測図

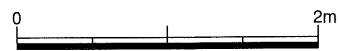

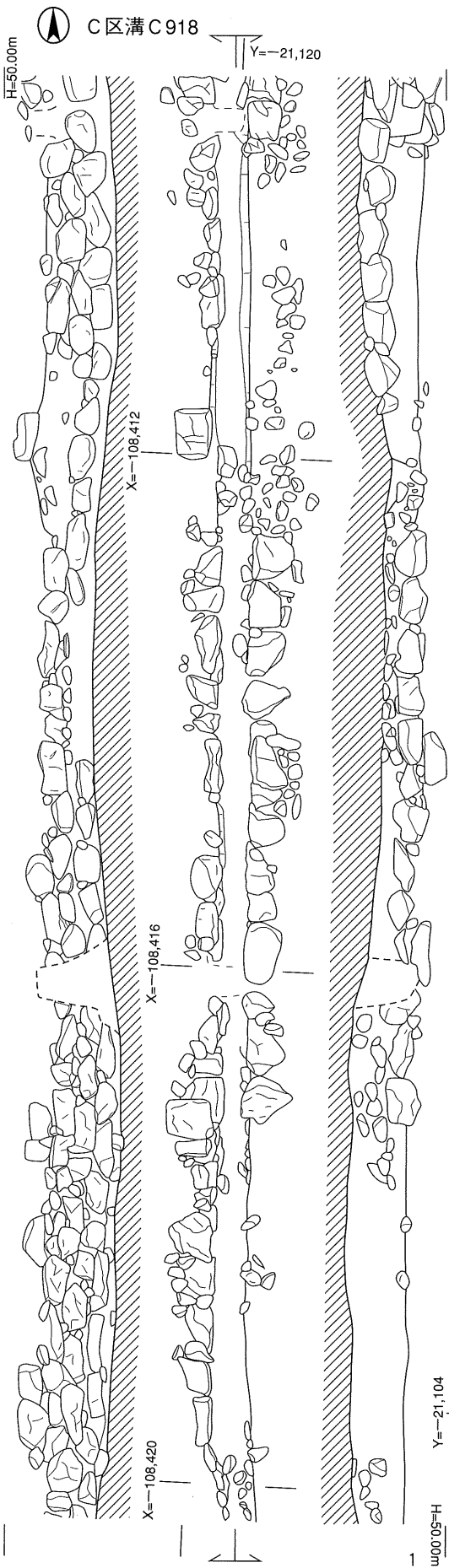

1 C区溝C918実測図

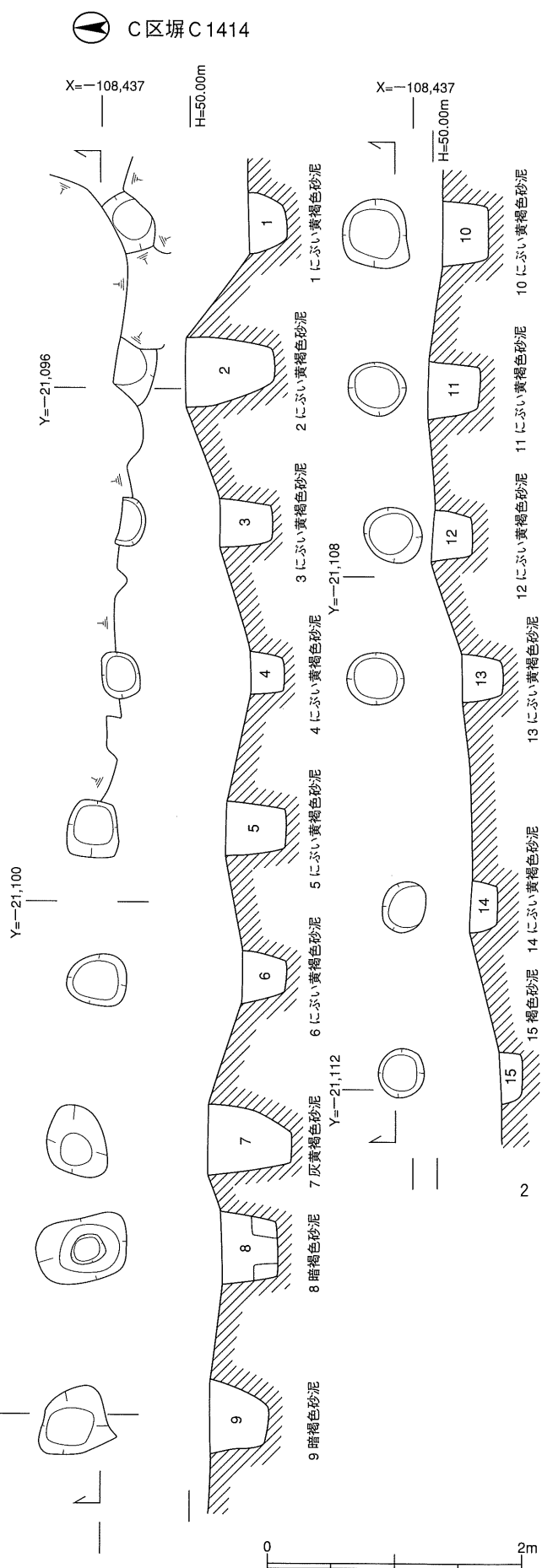

2 C区堀C1414実測図

① C区井戸C661

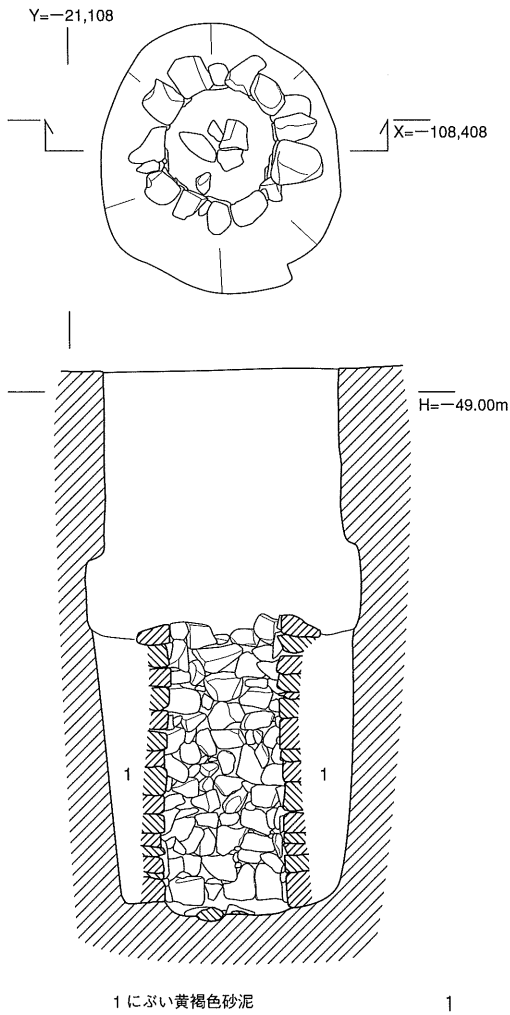

② C区井戸C952

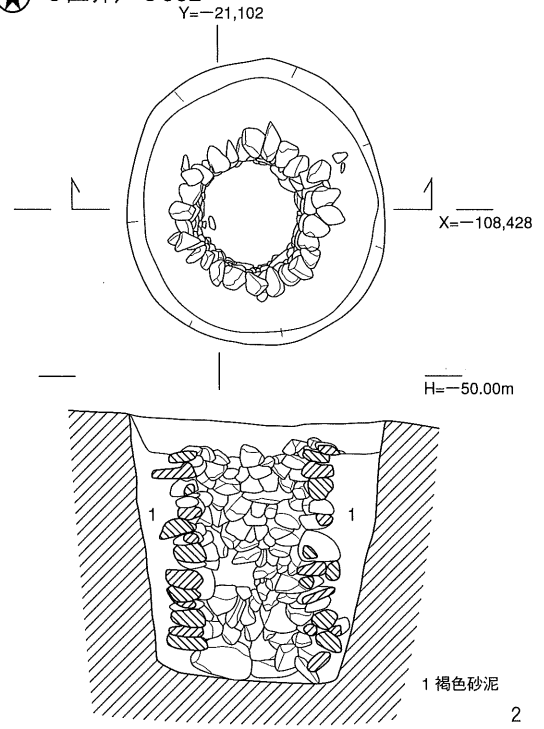

③ C区井戸C1192

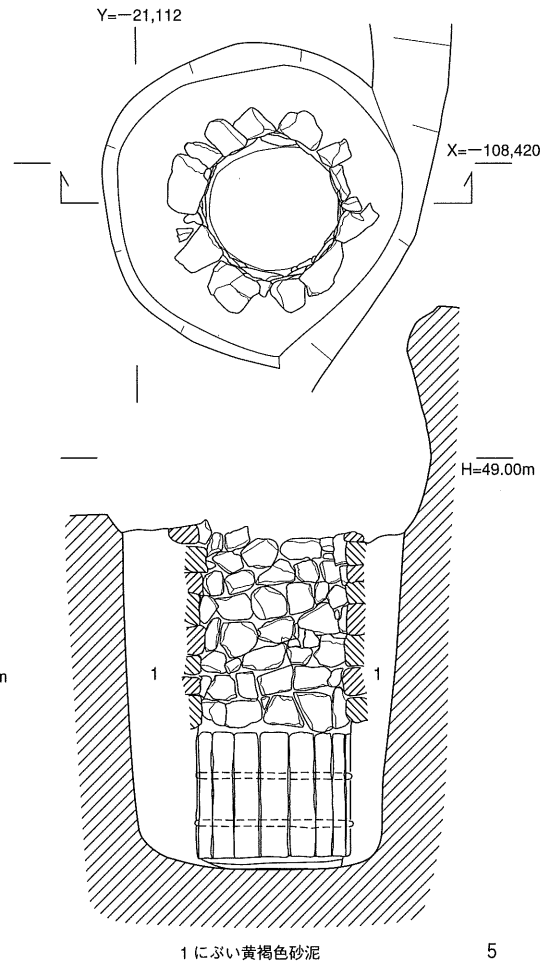

④ C区埋納土壙C494

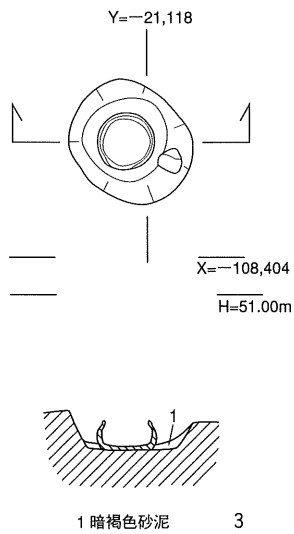

⑤ C区埋納土壙C342

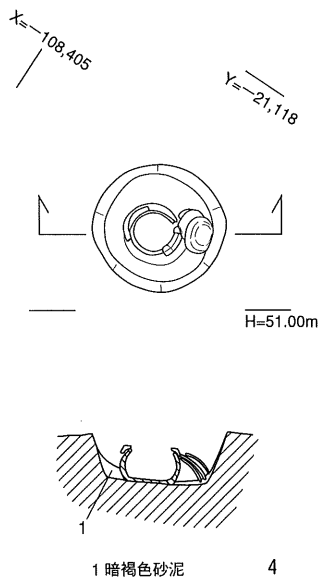

1 C区井戸C661実測図 2 C区井戸C952実測図 3 C区埋納土壙C494実測図  
4 C区埋納土壙C342実測図 5 C区井戸C1192実測図

① C区井戸C660

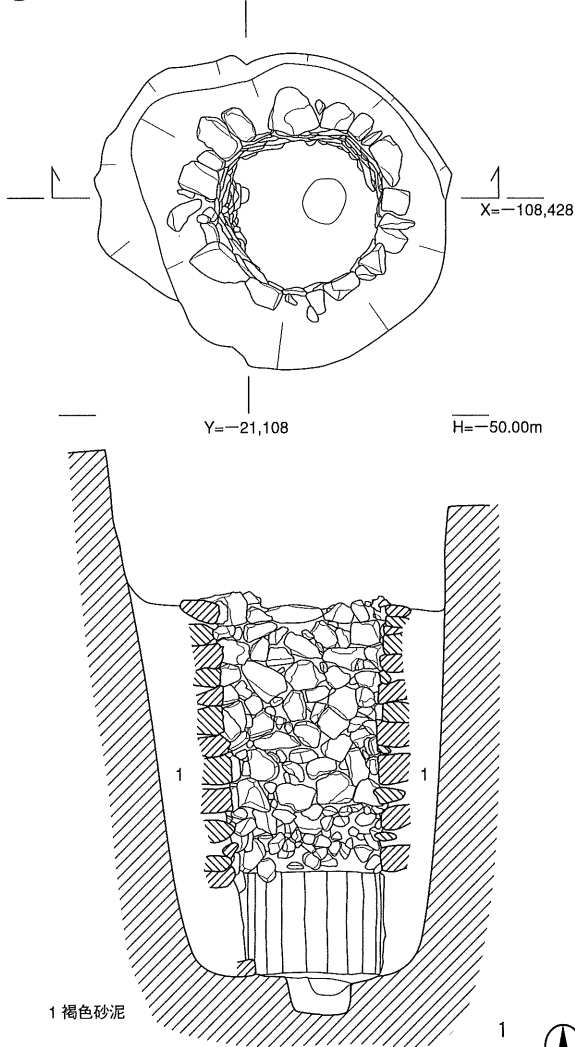

② C区溝C113・瓦組柵C153

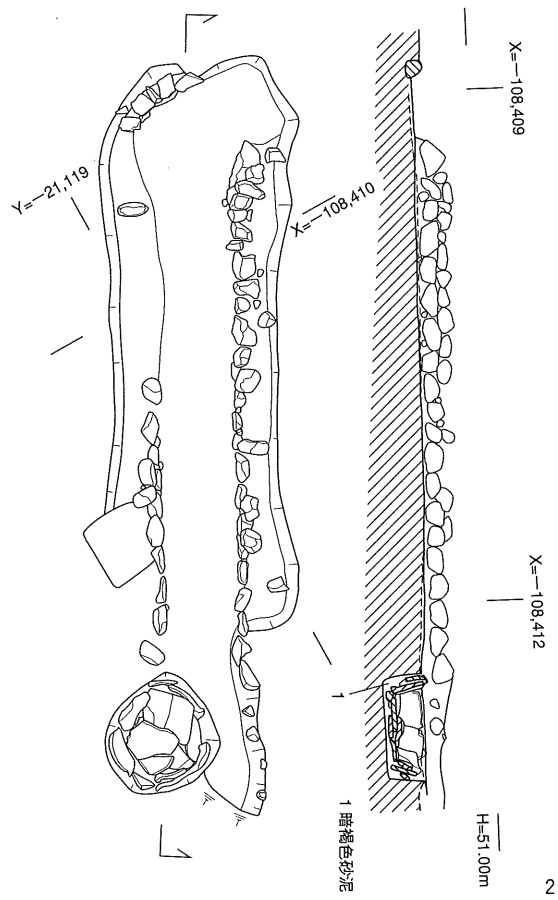

③ C区溝C35

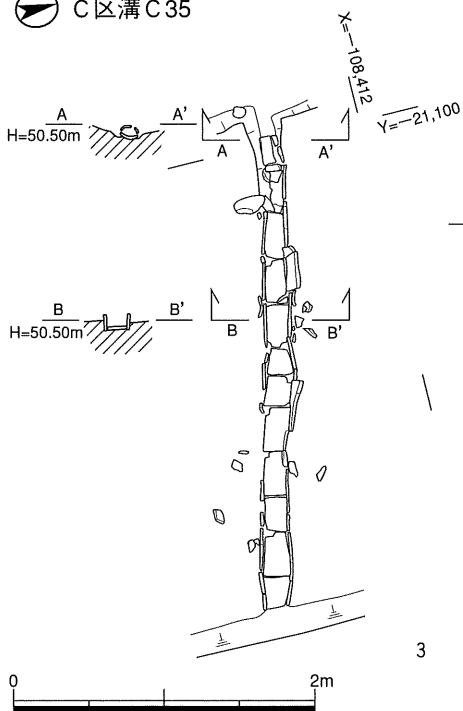

④ C区穴蔵C570

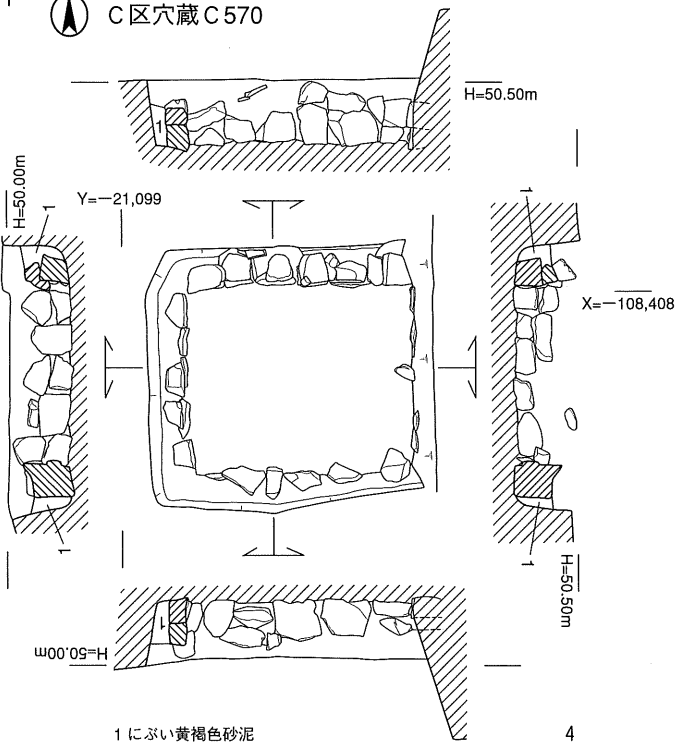

1 C区井戸C660実測図  
4 C区穴蔵C570実測図

2 C区溝C113・瓦組柵C153実測図

3 C区溝C35実測図



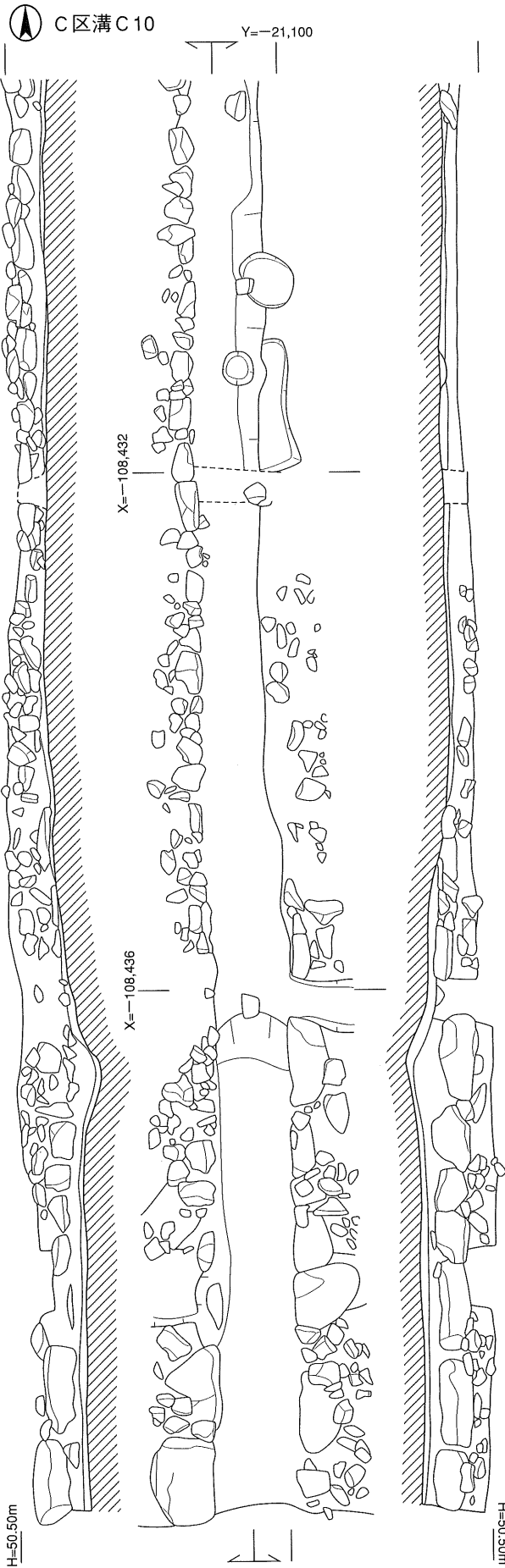

1 C区溝C10実測図

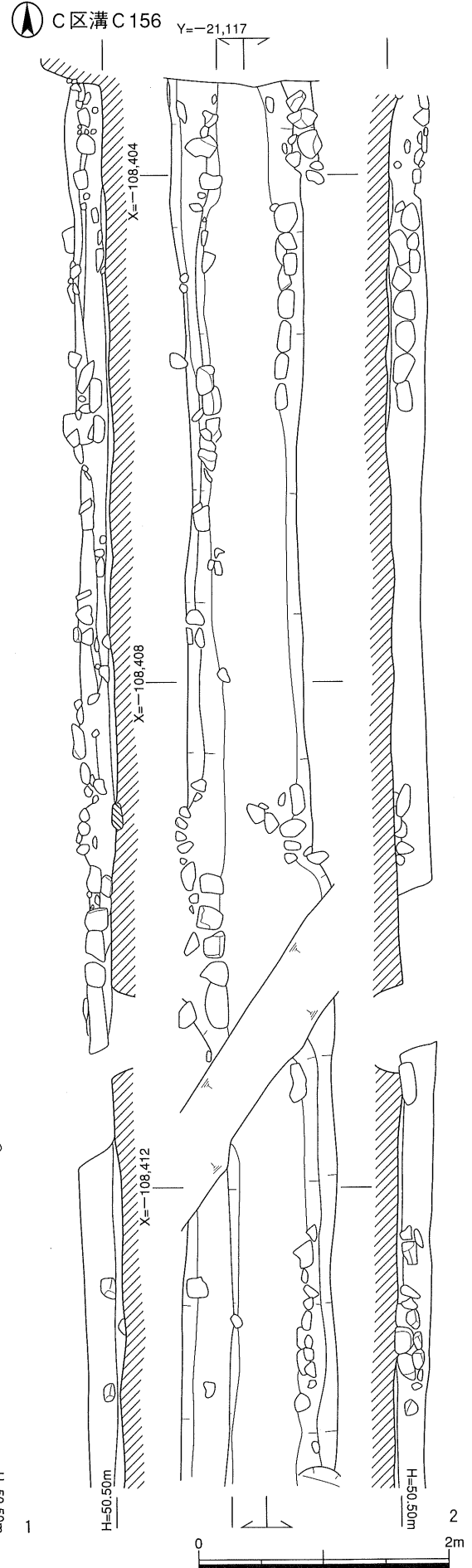

2 C区溝C156実測図

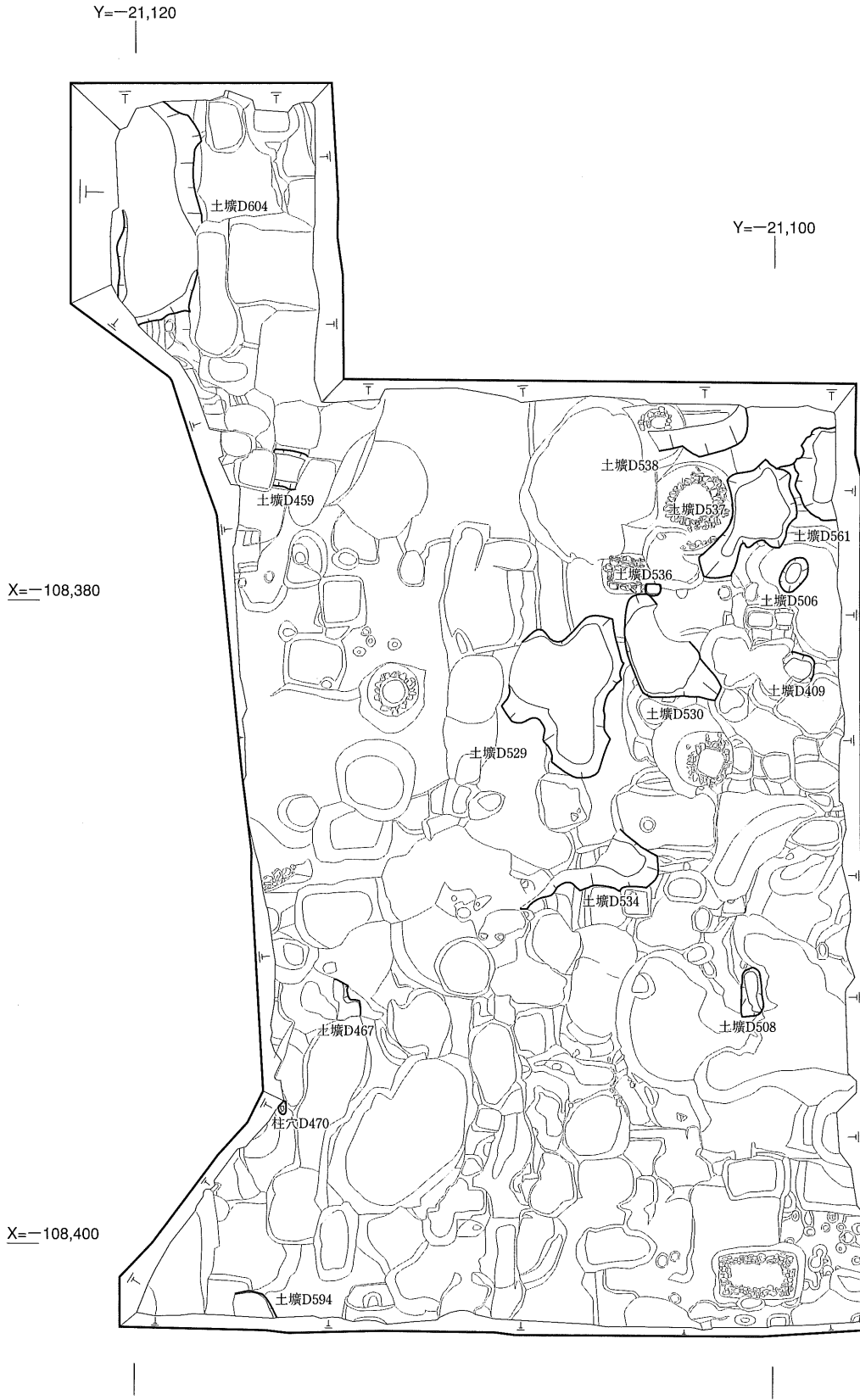

D区桃山期遺構平面図

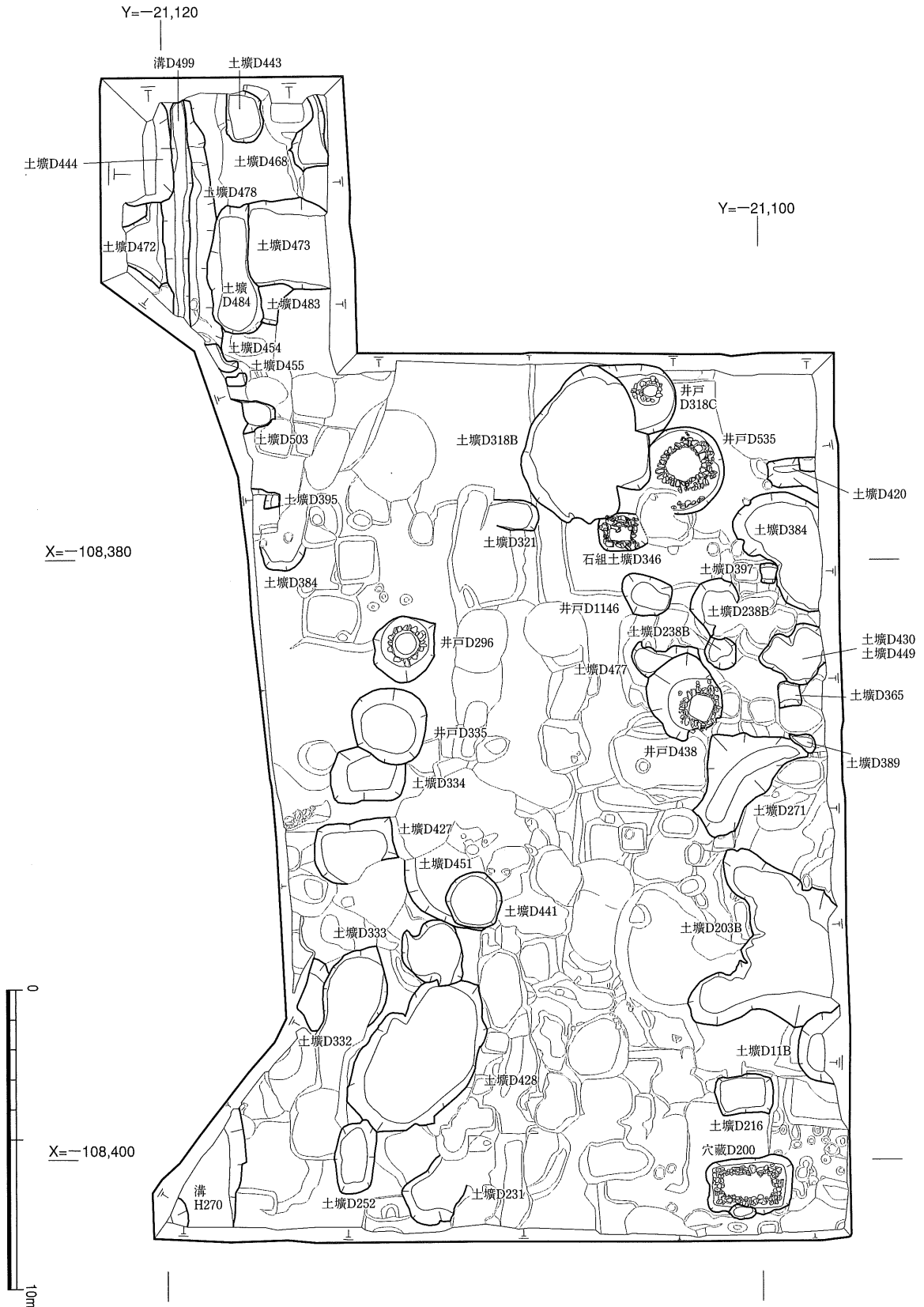

D区江戸時代前期遺構平面図

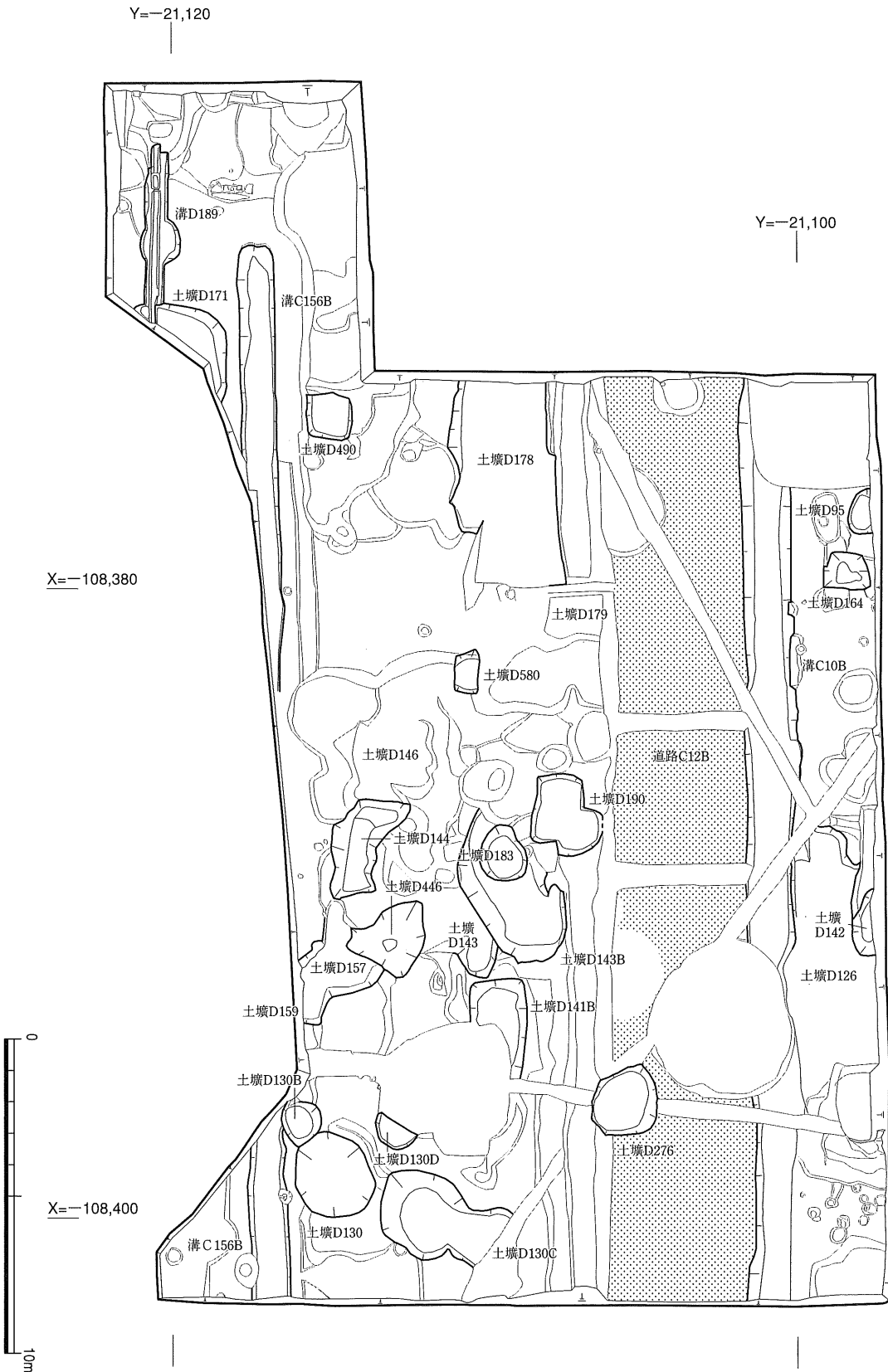

D区江戸時代中期遺構平面図

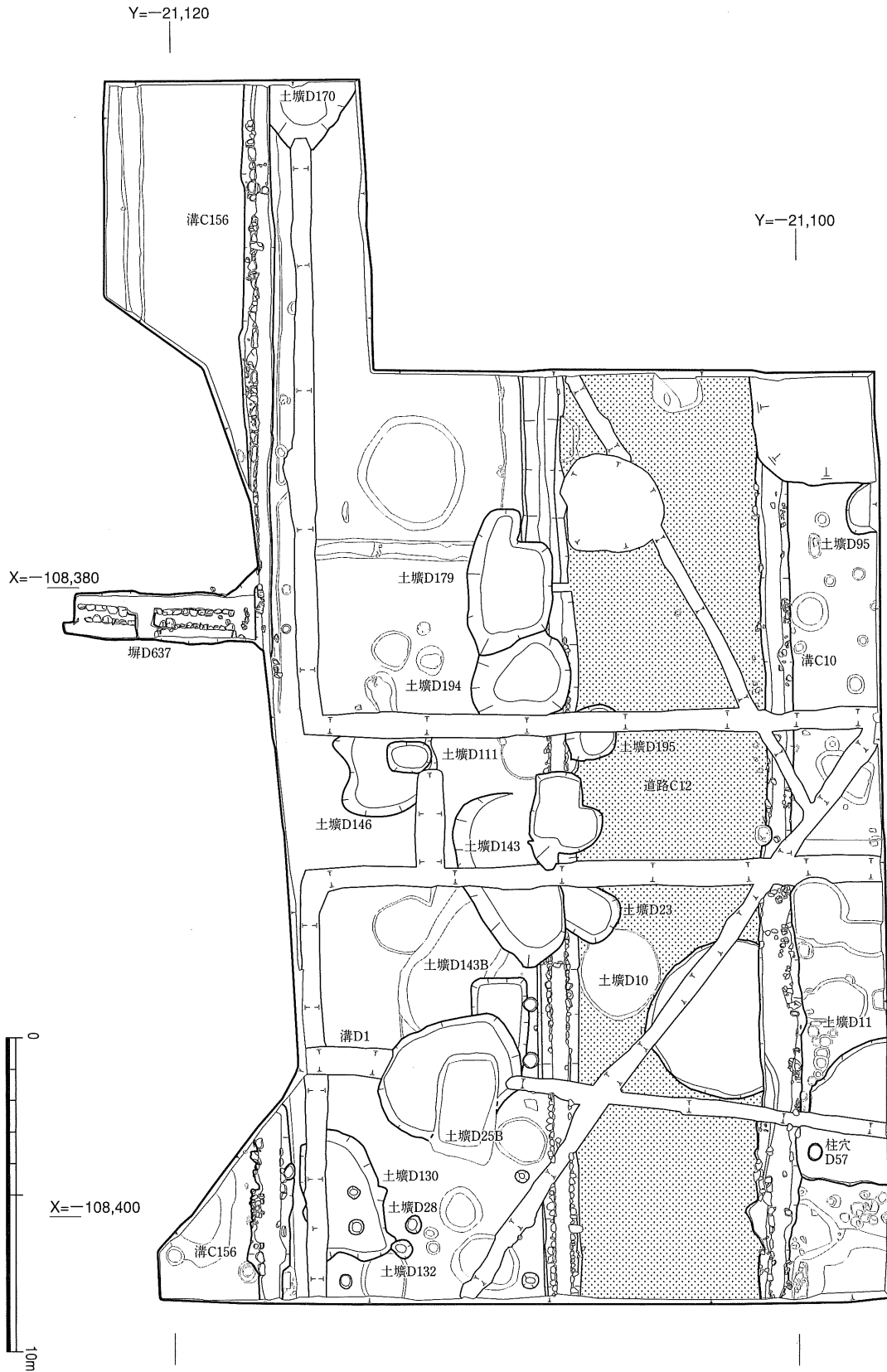

D区江戸時代後期遺構平面図

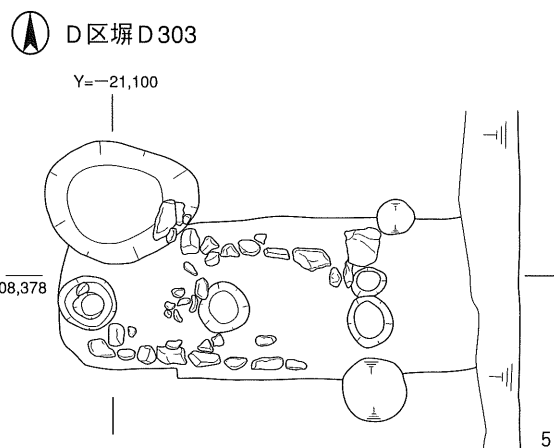
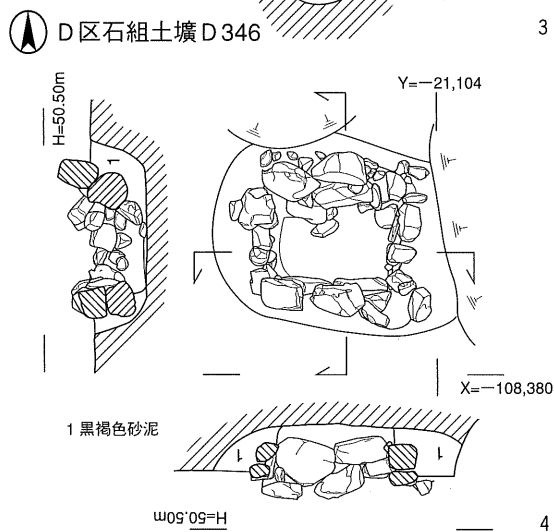
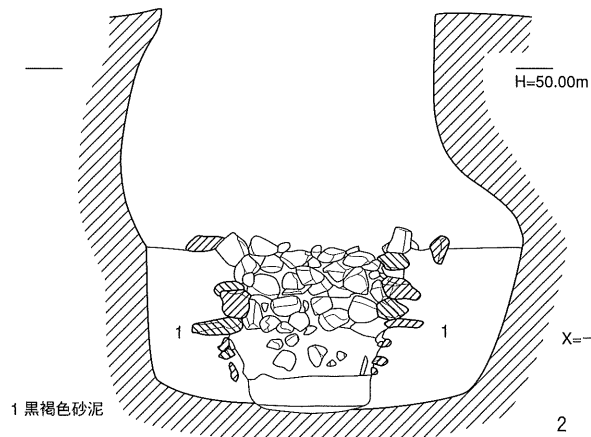
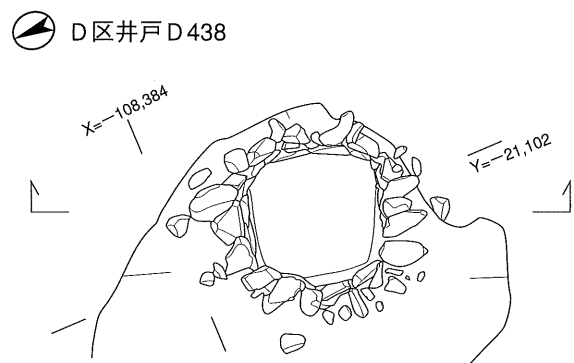
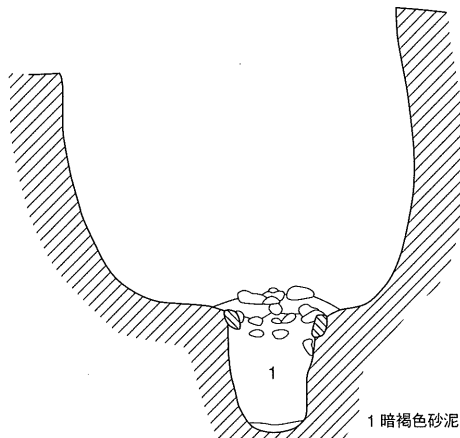
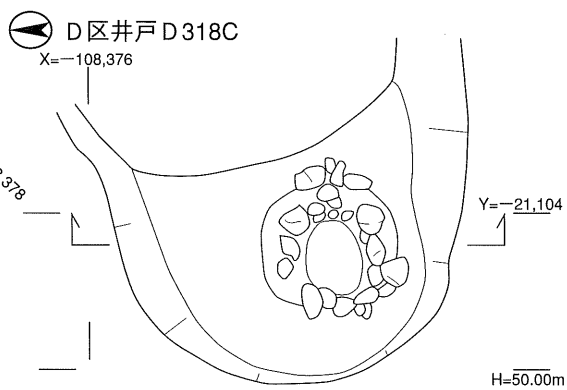
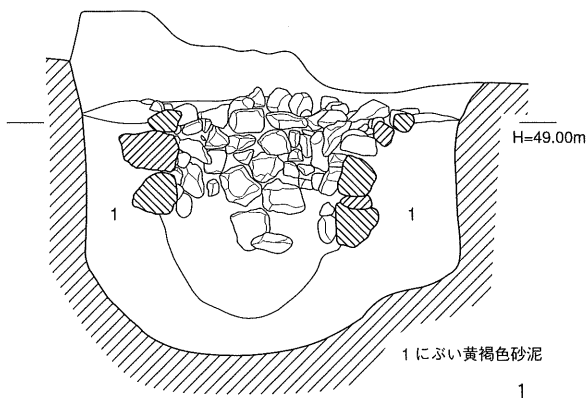
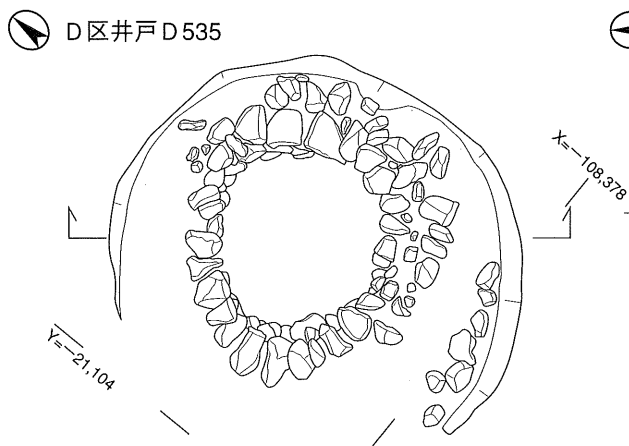

1 D区井戸 D535実測図    2 D区井戸 D438実測図    3 D区井戸 D318C実測図  
 4 D区石組土塙 D346実測図    5 D区塀 D303実測図

● D区井戸D296 X=-108,383 X=-108,384

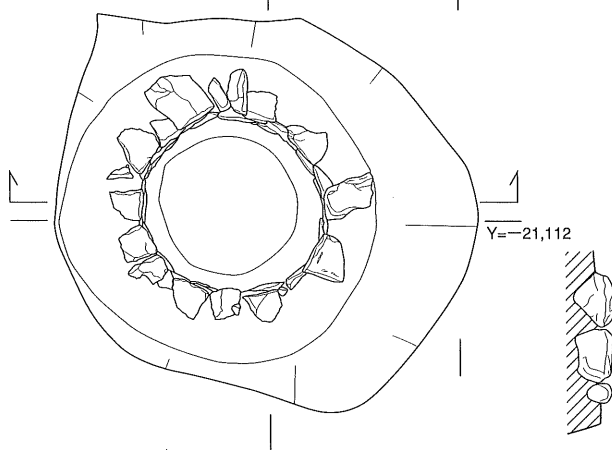

● D区塀D637

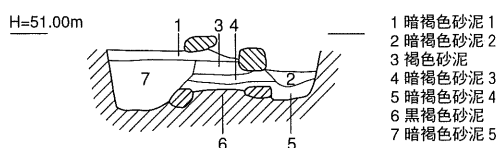

- 1 暗褐色砂泥
- 2 暗褐色砂泥
- 3 褐色砂泥
- 4 暗褐色砂泥
- 5 暗褐色砂泥
- 6 黒褐色砂泥
- 7 暗褐色砂泥

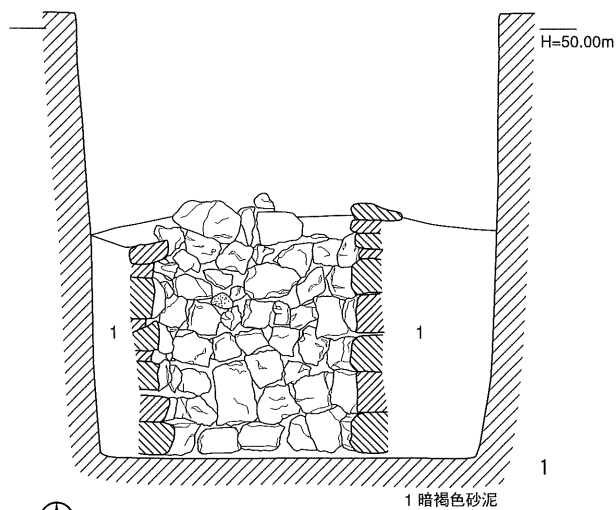
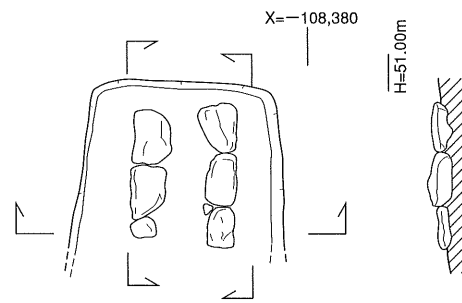

● D区穴蔵D200

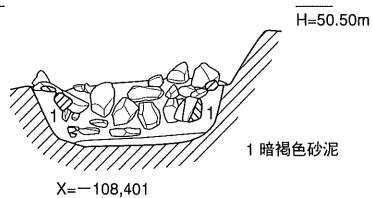

X=-108,401

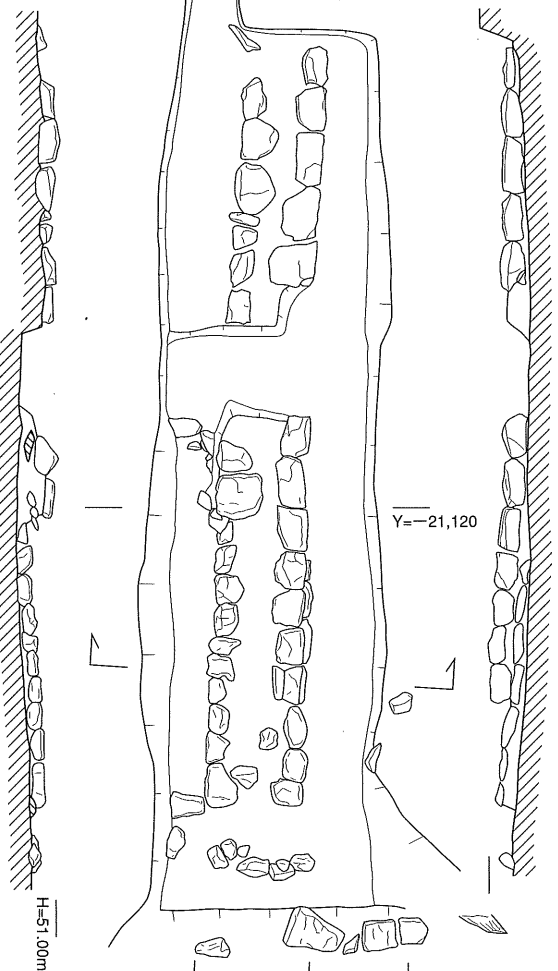
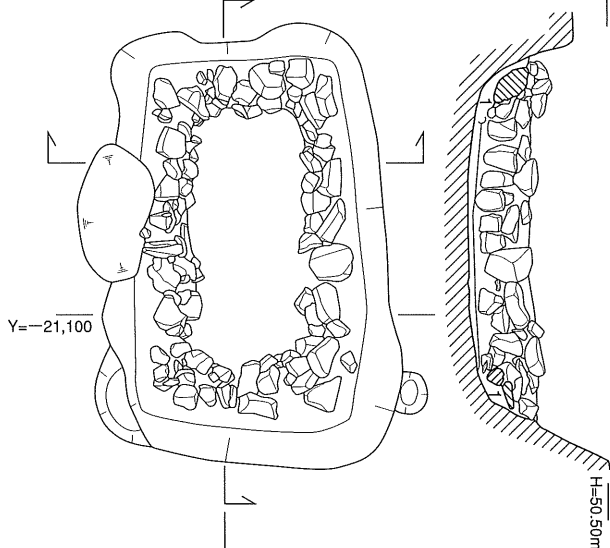

H=51.00m

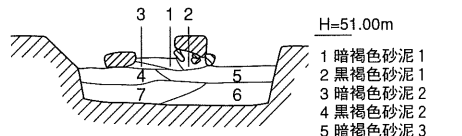

- 1 暗褐色砂泥
- 2 黒褐色砂泥
- 3 暗褐色砂泥
- 4 黒褐色砂泥
- 5 暗褐色砂泥
- 6 暗褐色砂泥
- 7 暗褐色砂泥



1 D区井戸D296実測図

2 D区穴蔵D200実測図

3 D区塀D637実測図



E区北部・L区桃山期遺構平面図

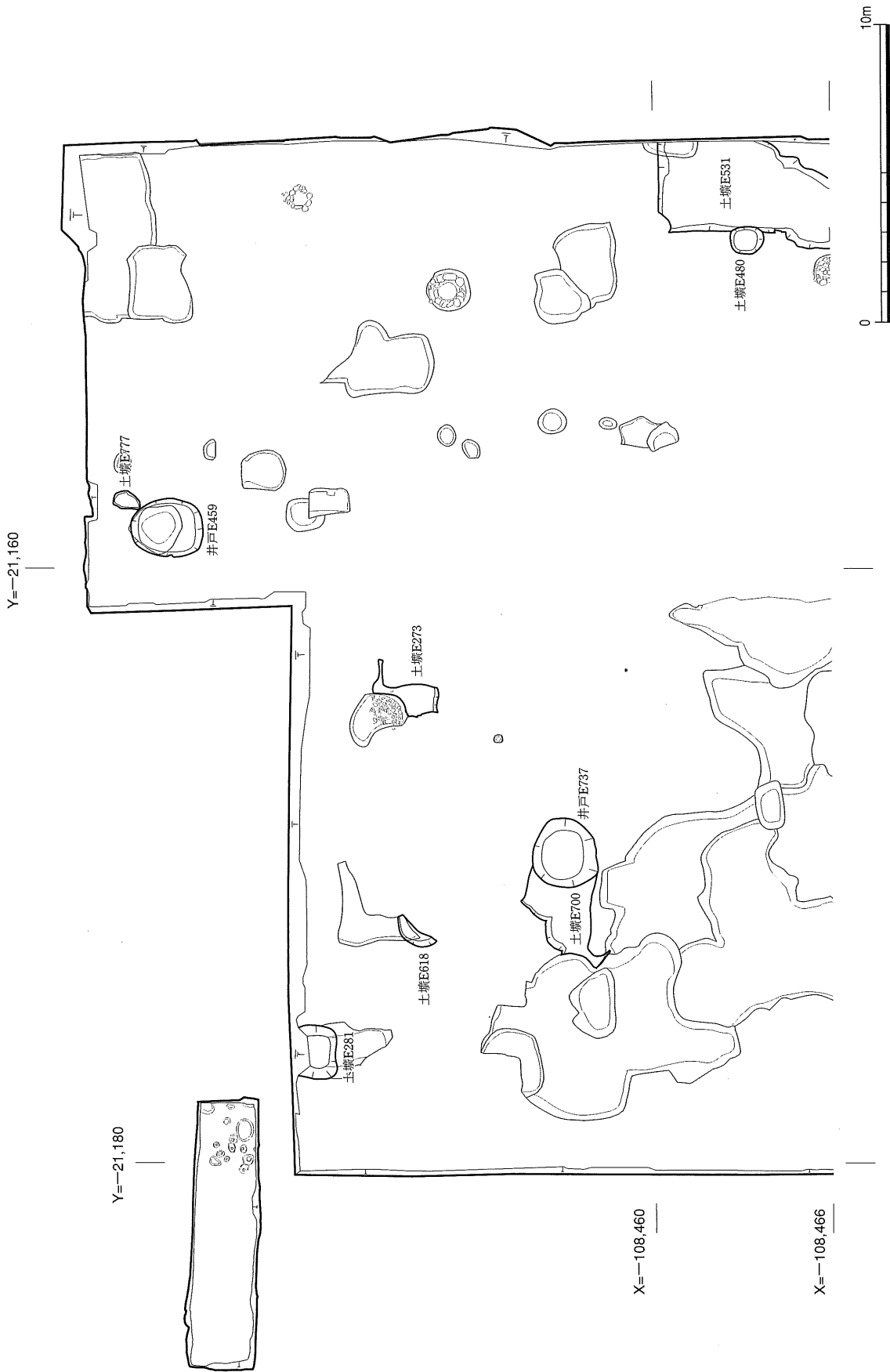



E区南部桃山期遺構平面図



Y=-21,160

Y=-21,180

X=-108,466

X=-108,480

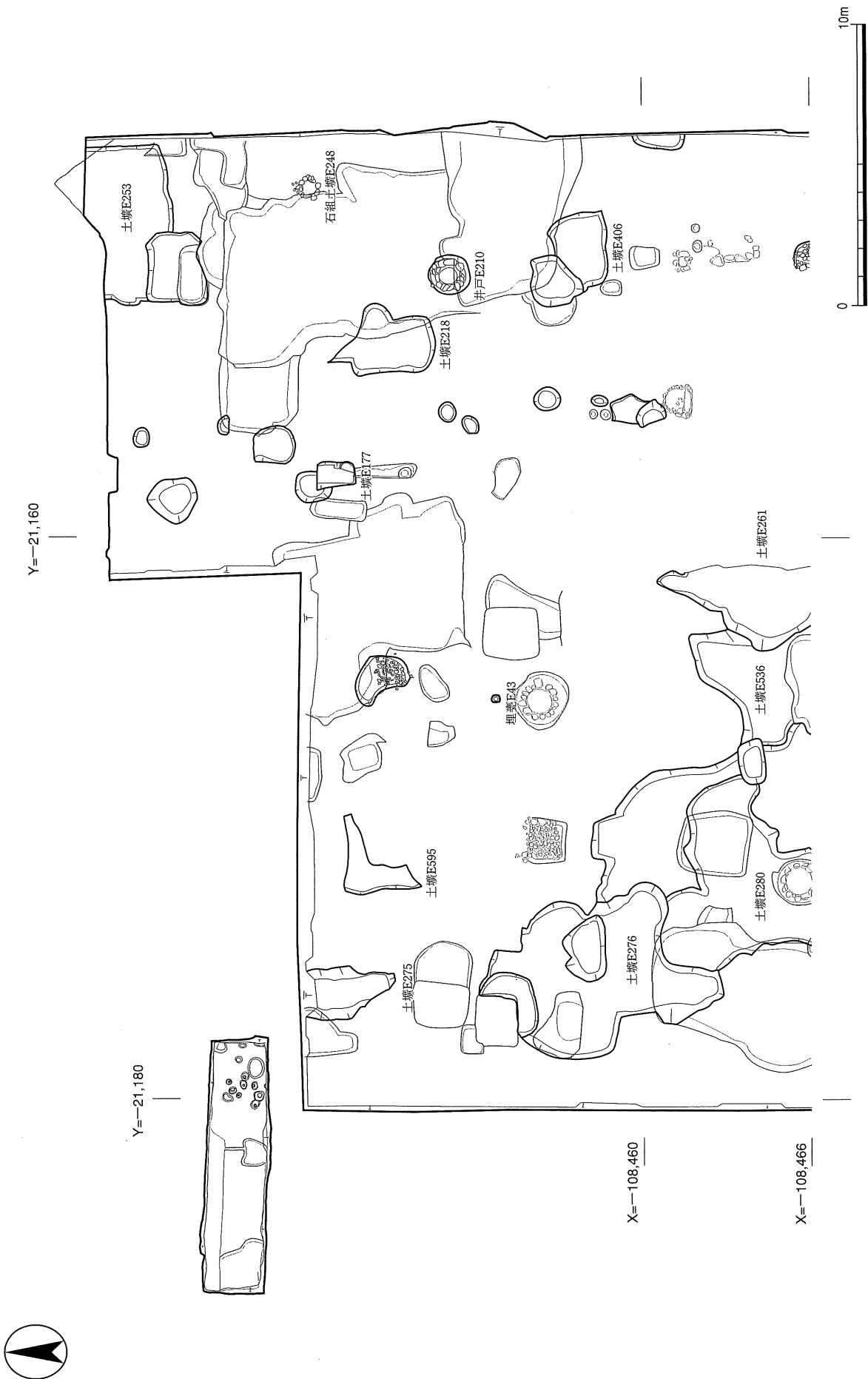

E区北部・L区江戸時代前期遺構平面図





E区北部・L区江戸時代中期遺構平面図

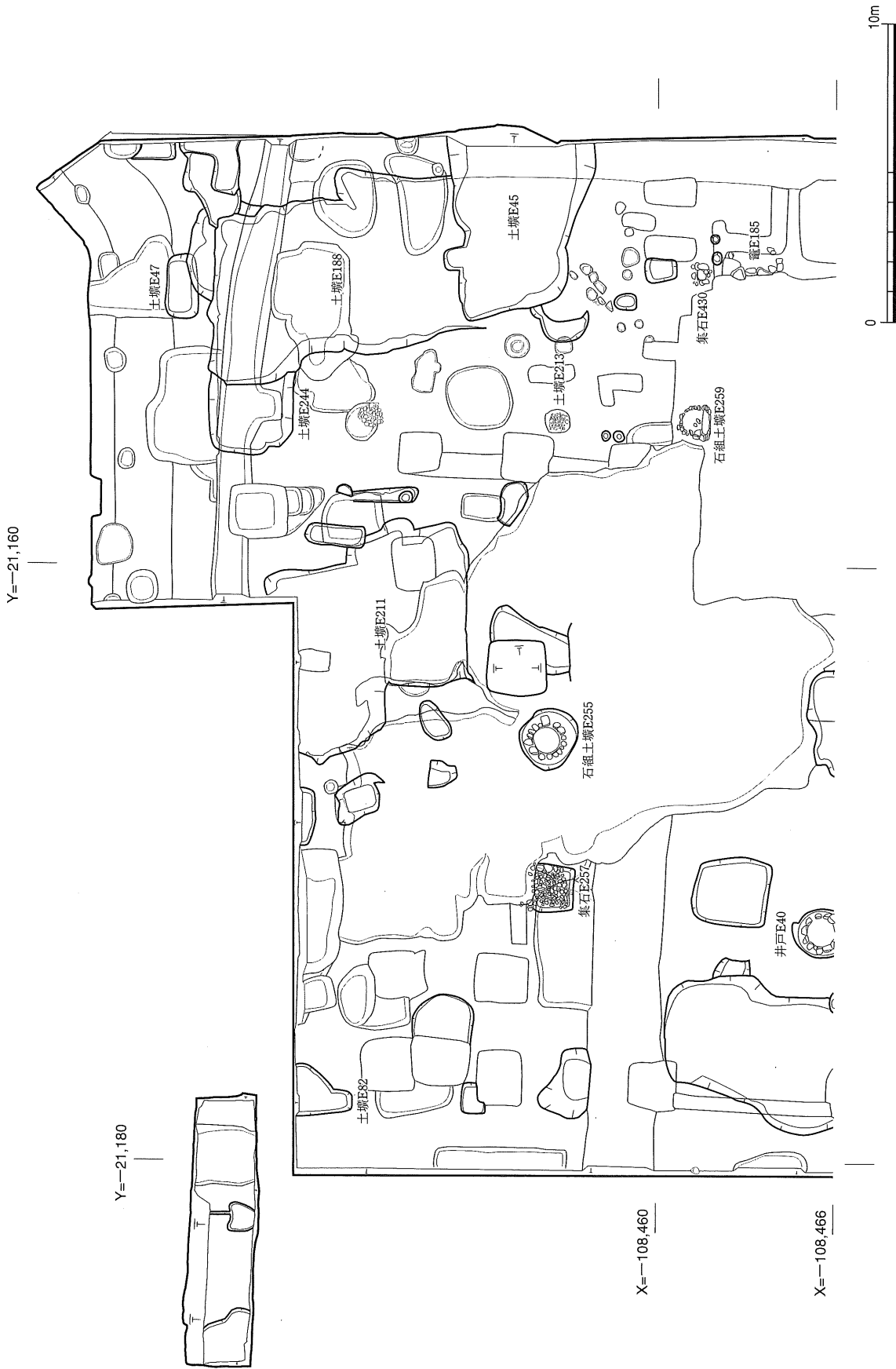



E区南部江戸時代中期遺構平面図

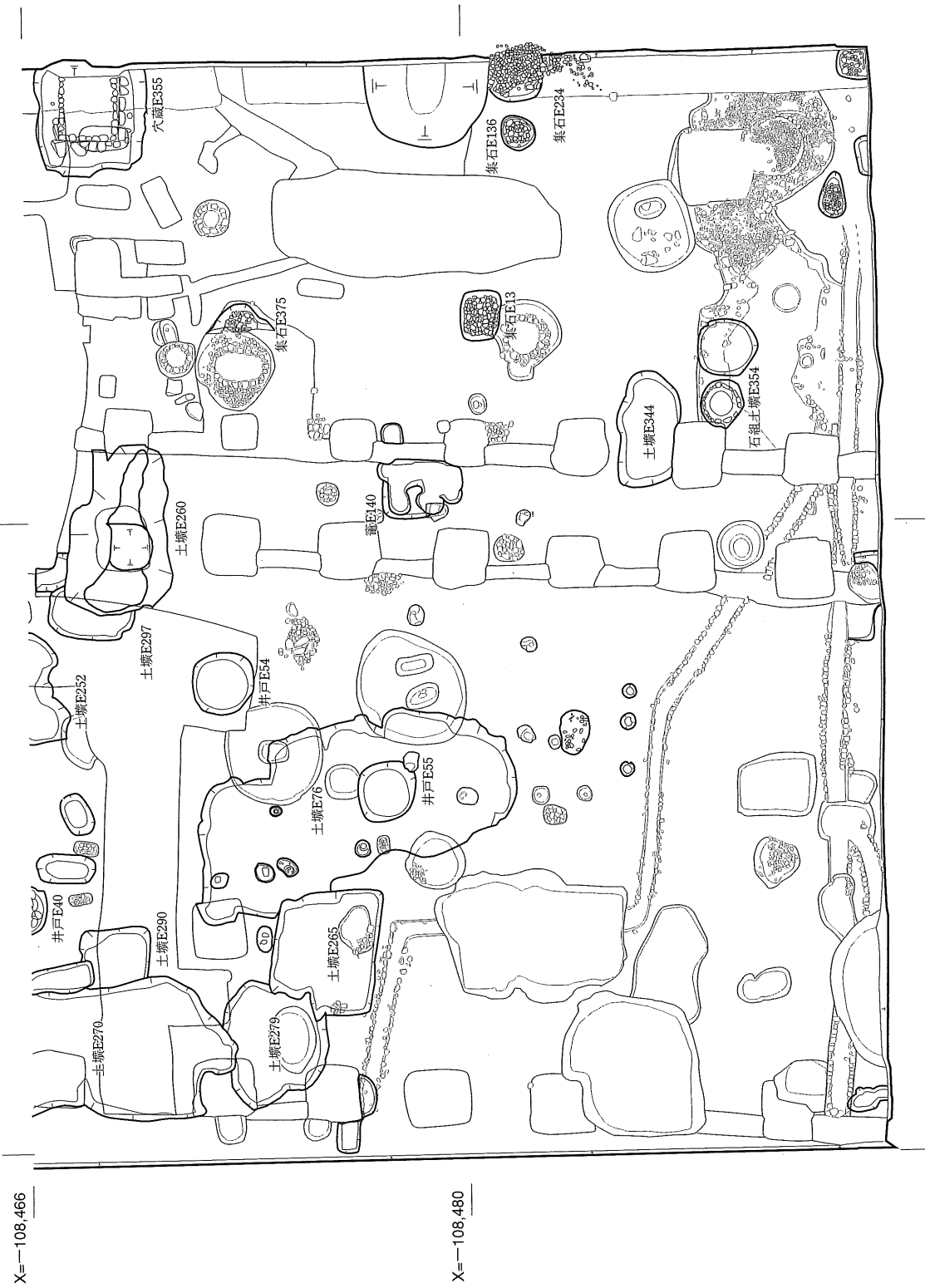

X=-108,466

X=-108,480

Y=-21,180

Y=-21,160





E区北部・L区江戸時代後期遺構平面図

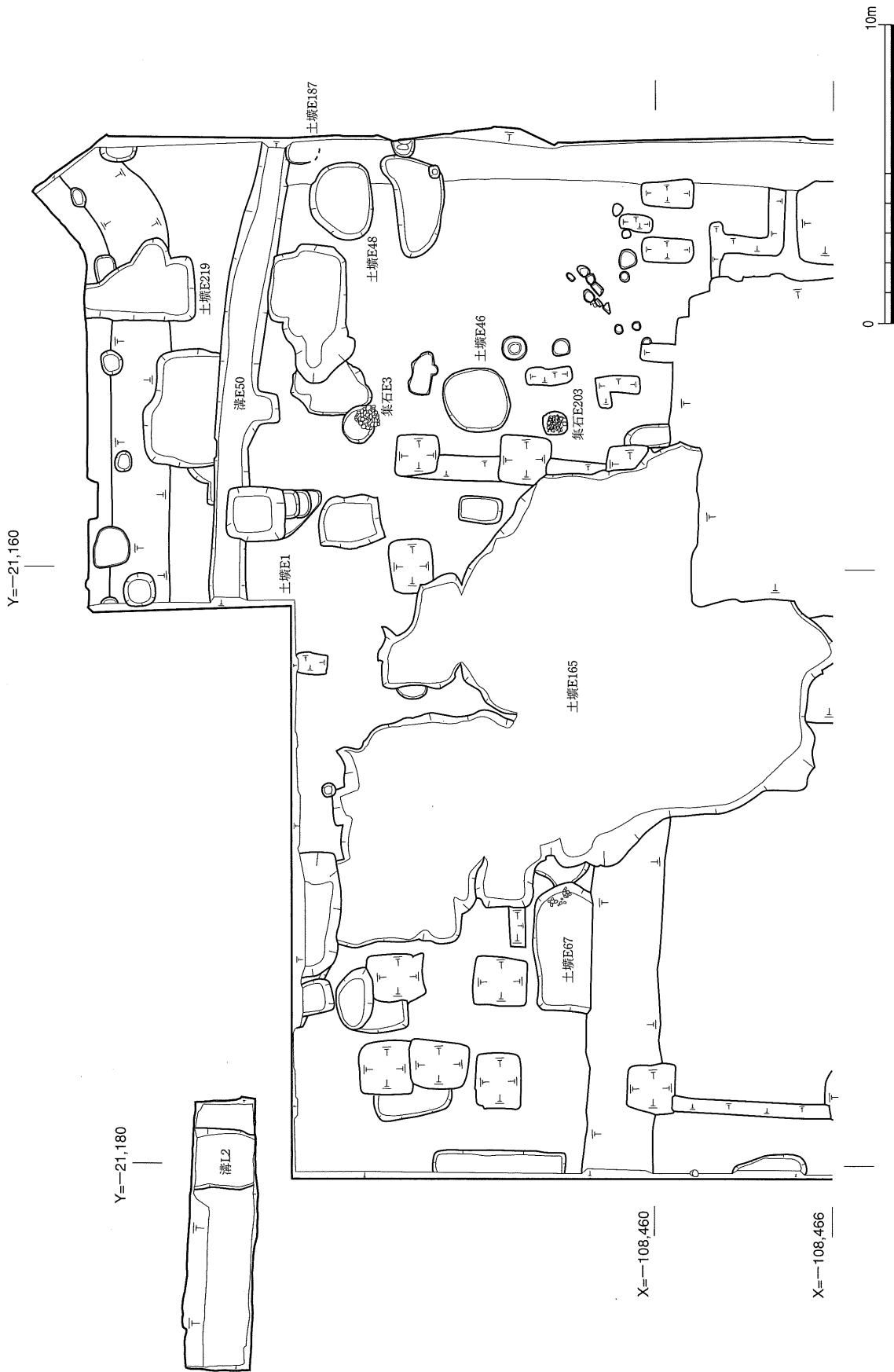



E区南部江戸時代後期遺構平面図

X=-108,466

X=-108,480

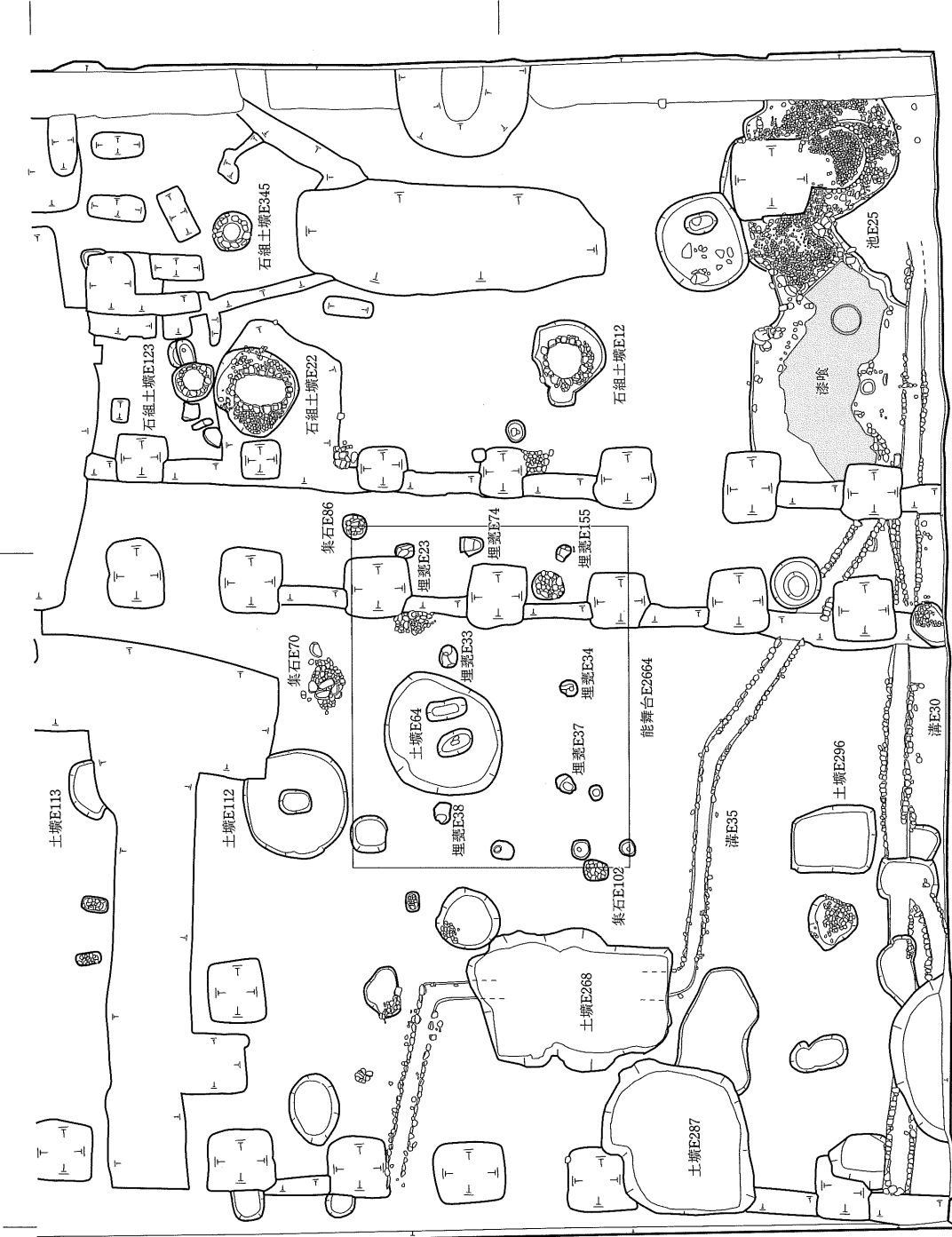

Y=-21,180

Y=-21,160

0 10m

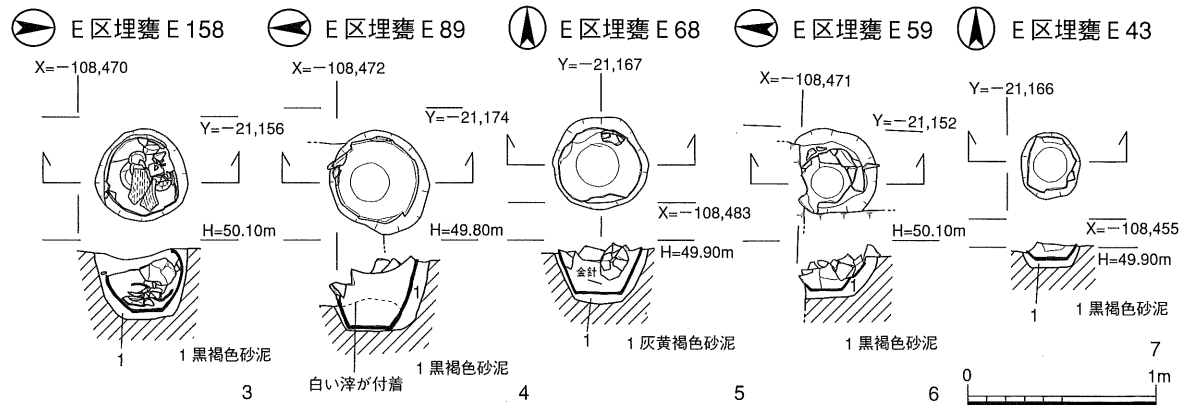
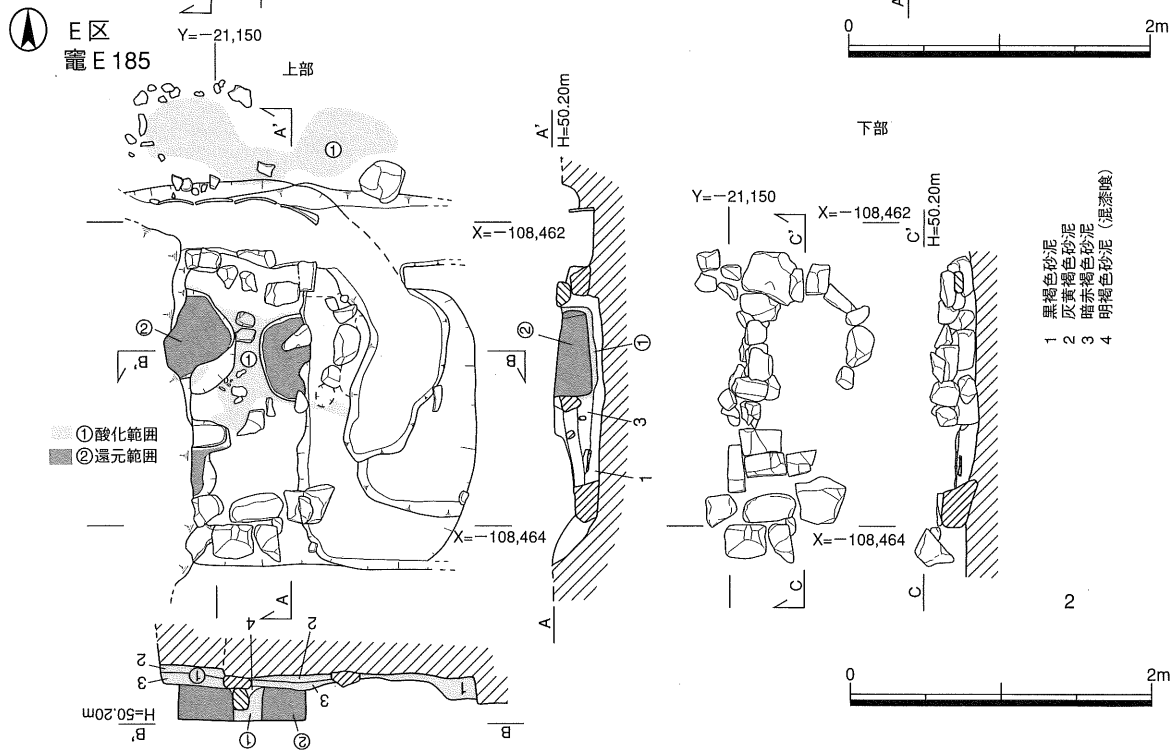
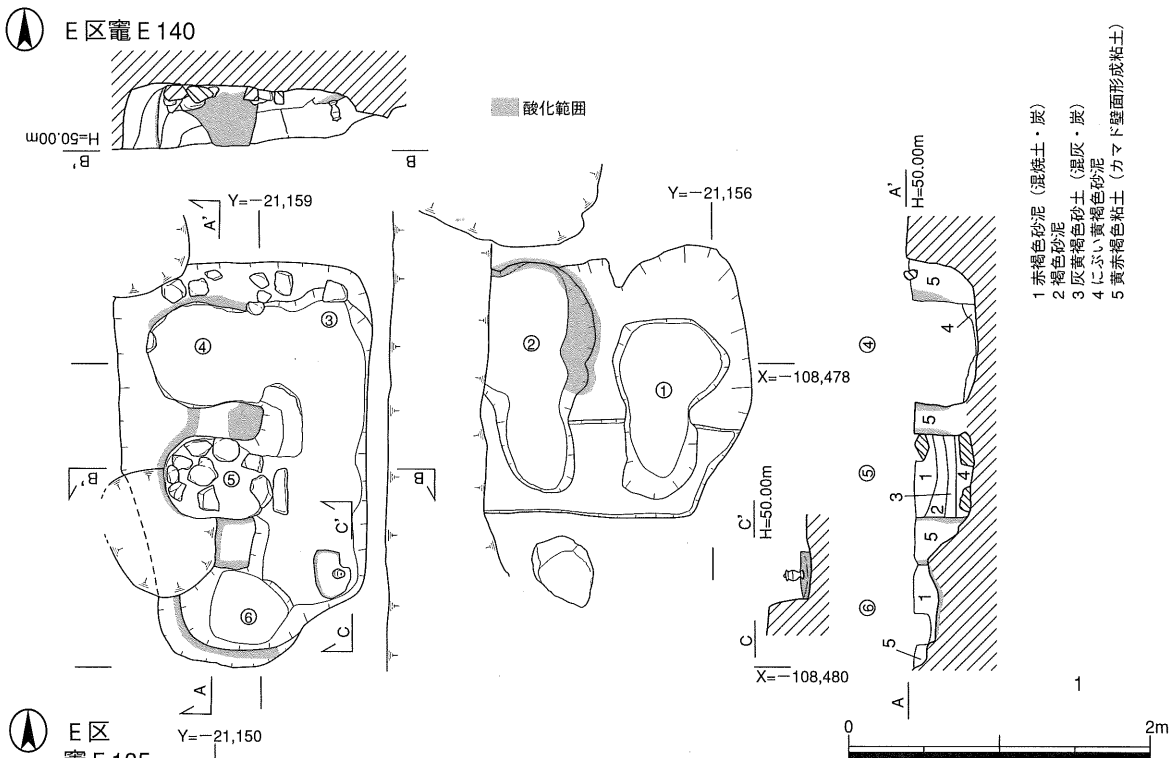

1 E区竈E140実測図   2 E区竈E185実測図   3 E区埋甕E158実測図   4 E区埋甕E89実測図  
5 E区埋甕E68実測図   6 E区埋甕E59実測図   7 E区埋甕E43実測図

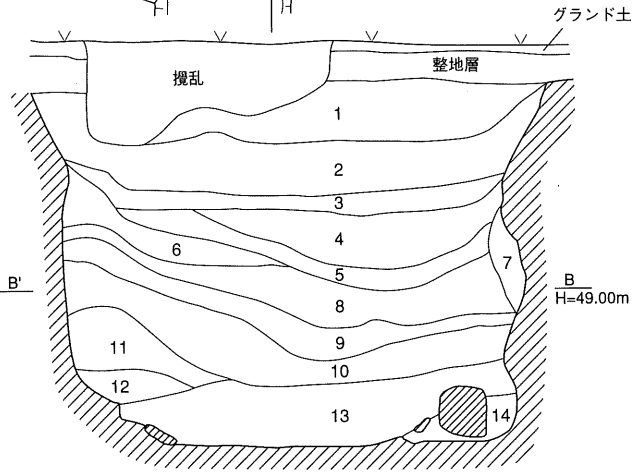
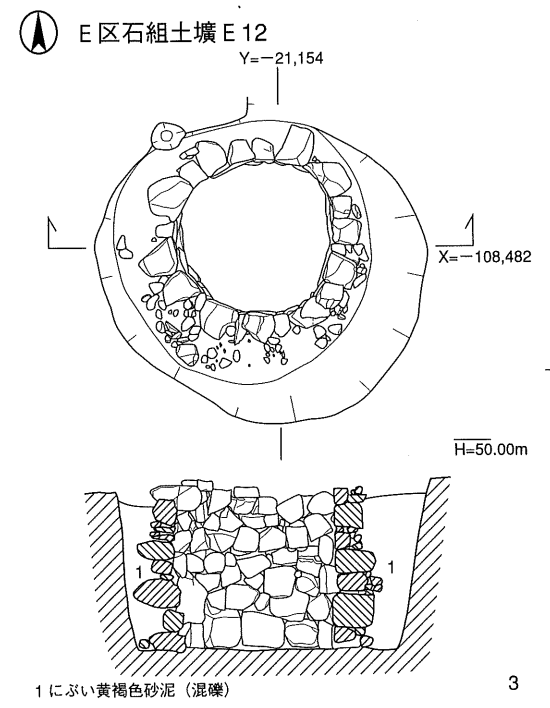
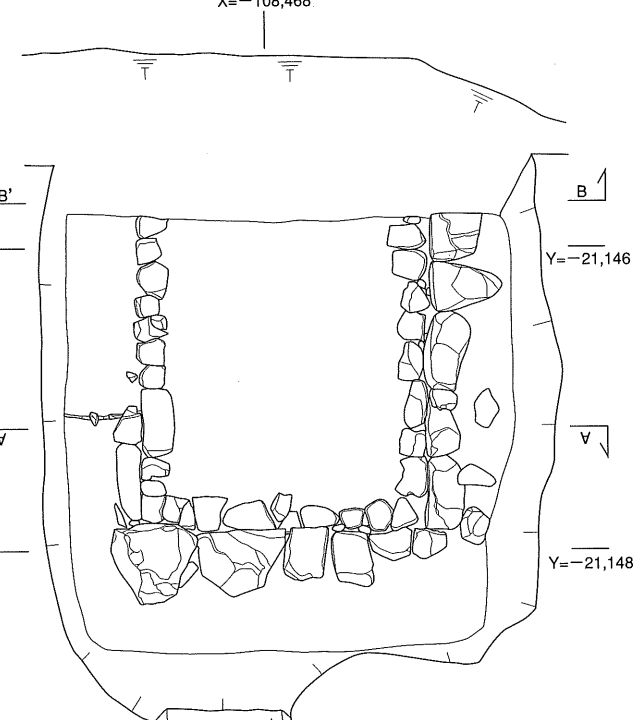
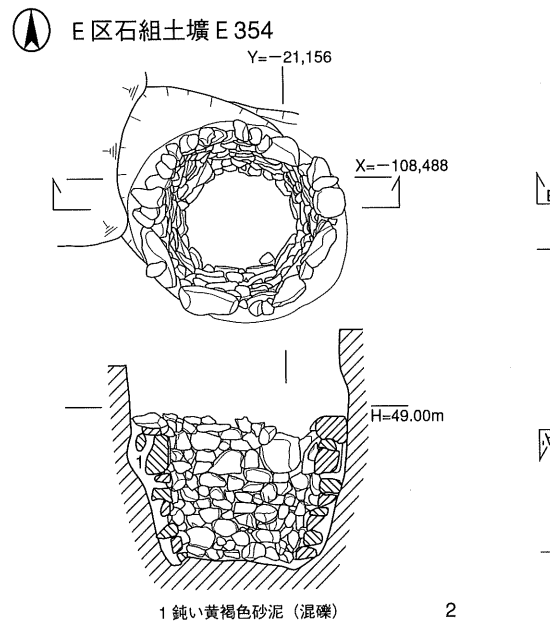
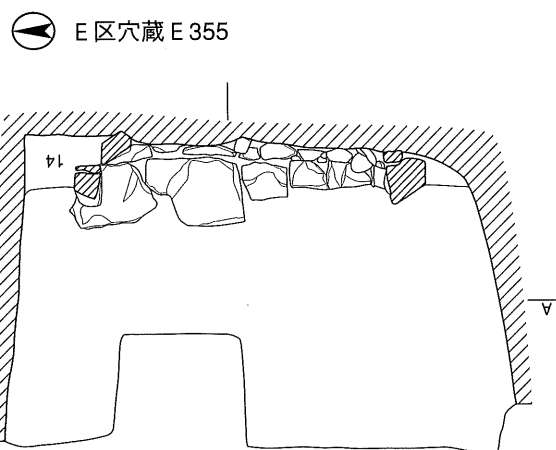
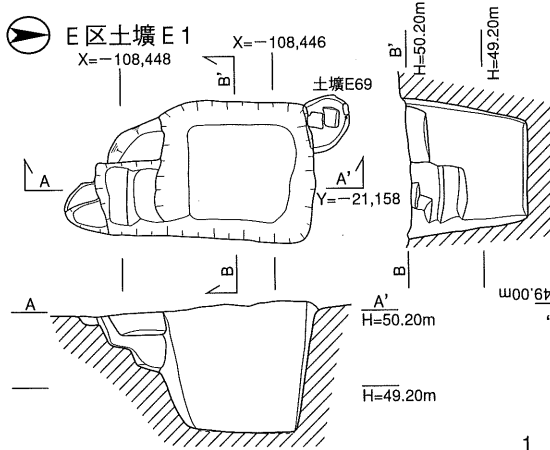

- 1 黒褐色砂泥
- 2 灰褐色砂泥
- 3 黒褐色砂泥 (混焼土)
- 4 褐色砂泥
- 5 灰黄褐色砂泥 (混炭)
- 6 褐色砂泥
- 7 褐灰色砂泥
- 8 褐色砂泥
- 9 にぶい黄褐色砂泥
- 10 褐色砂泥 (混焼土)
- 11 褐色砂泥 (混焼土)
- 12 にぶい黄褐色砂泥
- 13 にぶい黄褐色砂泥 (混礫)
- 14 にぶい黄褐色砂泥 (混焼土)

1 E 区土壌 E 1 実測図      2 E 区石組土壌 E 354 実測図      3 E 区石組土壌 E 12 実測図  
 4 E 区穴蔵 E 355 実測図

⊙ E区集石 E 203

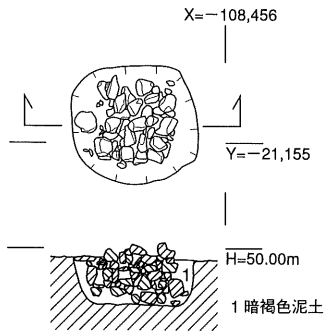

1

⊙ E区集石 E 430

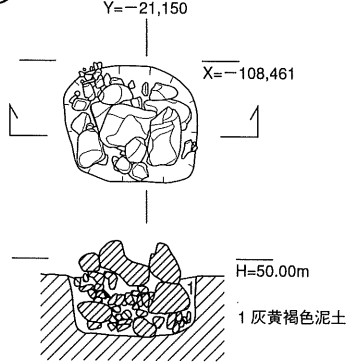

2

⊙ E区集石 E 136

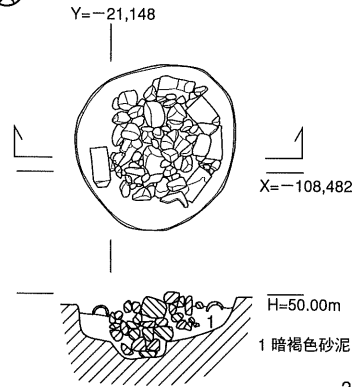

3

⊙ E区集石 E 257

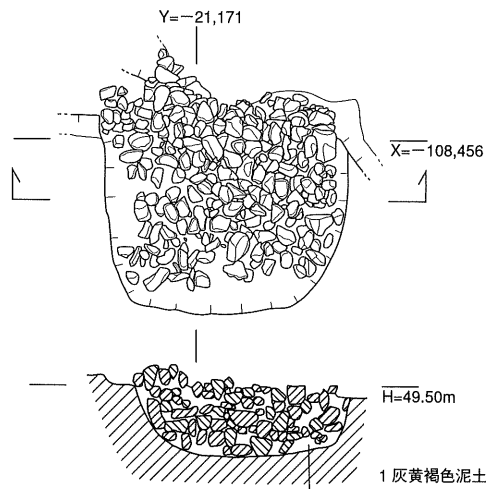

4

⊙ E区集石 E 234

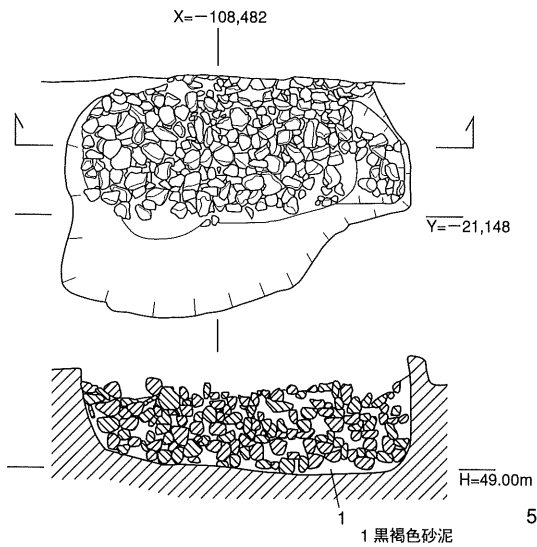

5

⊙ E区集石 E 134

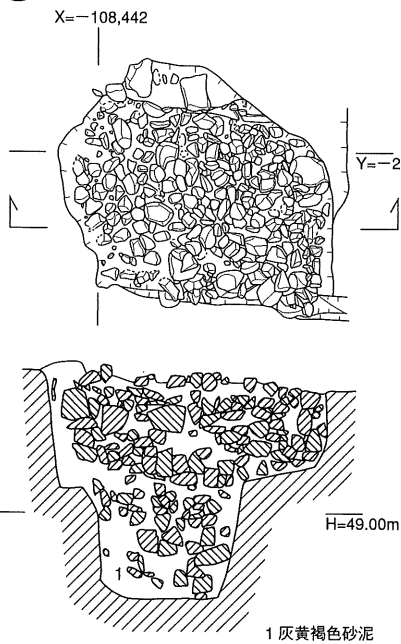

6

⊙ E区石組土壙 E 123

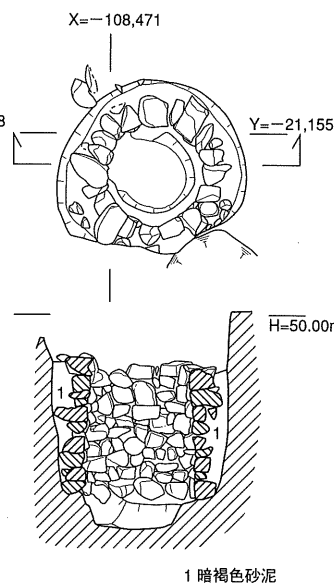

7

⊙ E区石組土壙 E 371

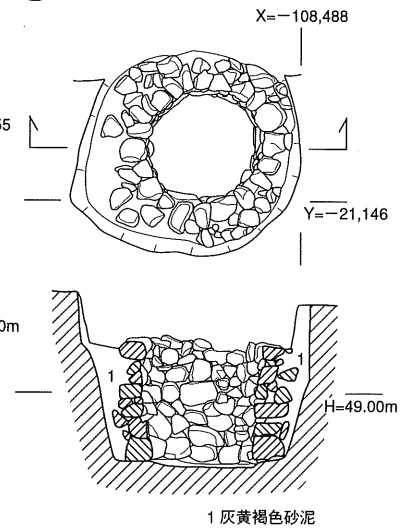

8



1 E区集石 E 203实测图

2 E区集石 E 430实测图

3 E区集石 E 136实测图

4 E区集石 E 257实测图

5 E区集石 E 234实测图

6 E区集石 E 134实测图

7 E区石組土壙 E 123实测图

8 E区石組土壙 E 371实测图

图版一十七 封土

Y=-21,176

X=-108,484

⊙ E区溝 E 35

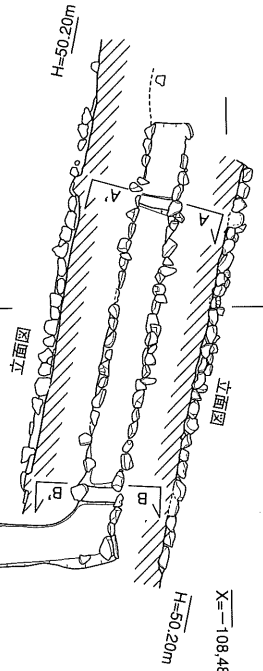

1:0.25=H

平面图

立面图

H=50.20m

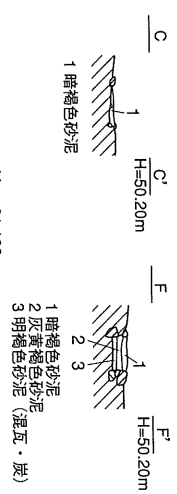
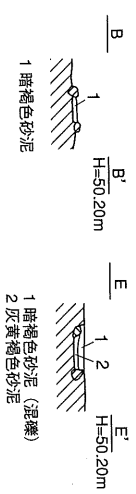
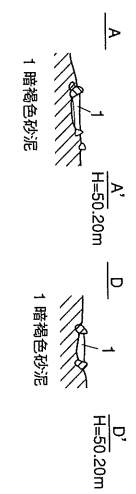

Y=-21,172

Y=-21,168

H=50.20m

Y=-21,164

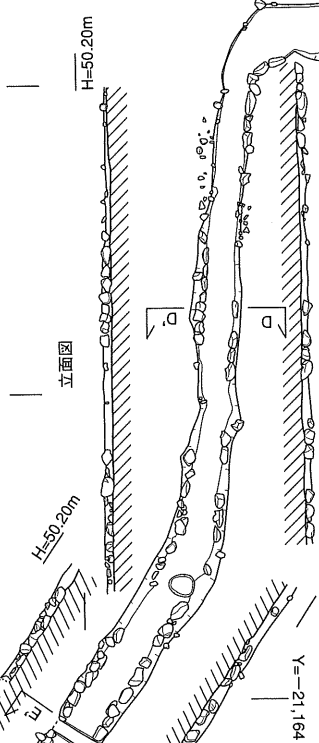

1:0.25=H

H=50.20m

平面图

立面图

H=50.20m

平面图

Y=-21,160

Y=-21,160

H=50.20m

立面图

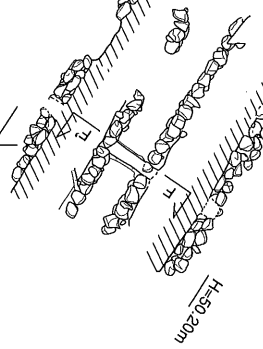

E区溝 E 35实测图

① E区溝 E30

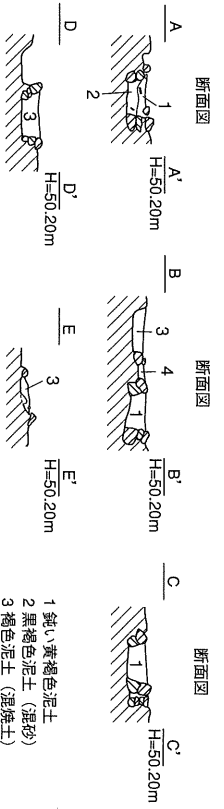
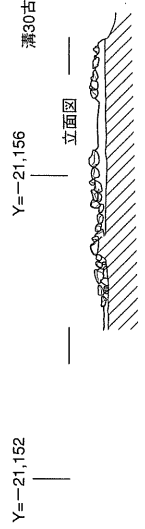
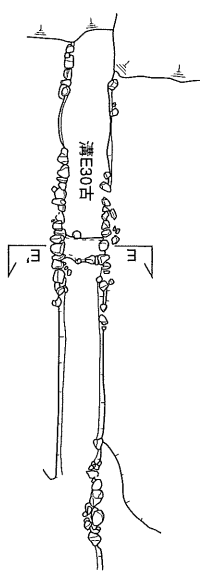
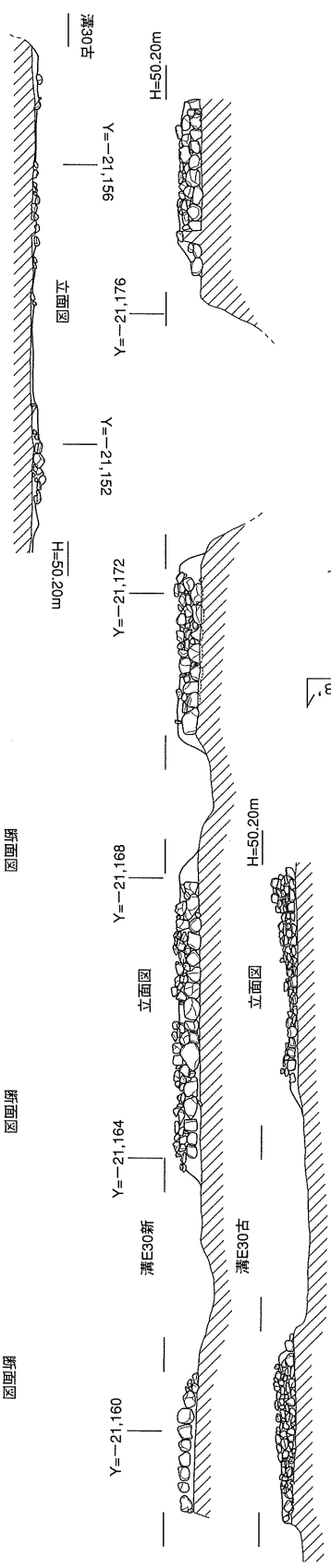
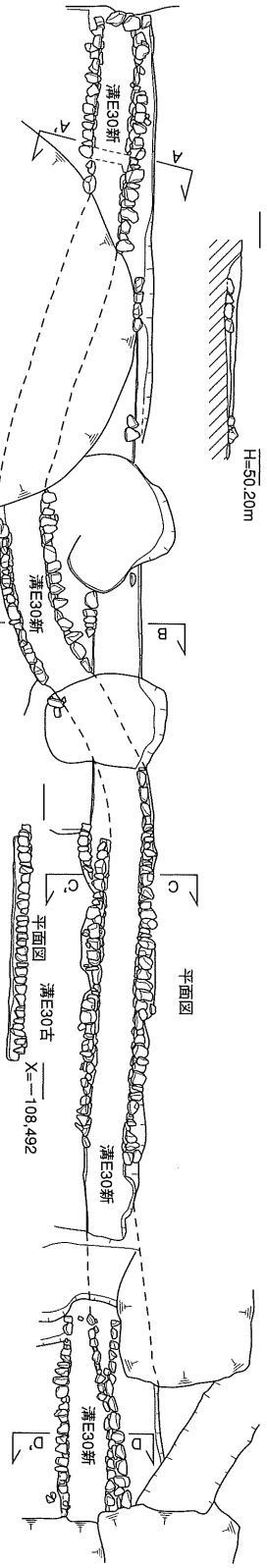
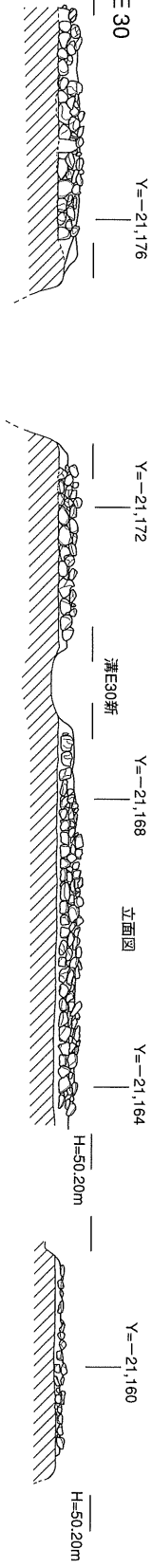

- 1 鈍い黄褐色泥土
- 2 黒褐色泥土(混砂)
- 3 褐色泥土(混鉄土)
- 4 黒褐色砂泥



図版一七八 遺構

E区溝E30(新・古)実測図



● E区石組土塙 E 345

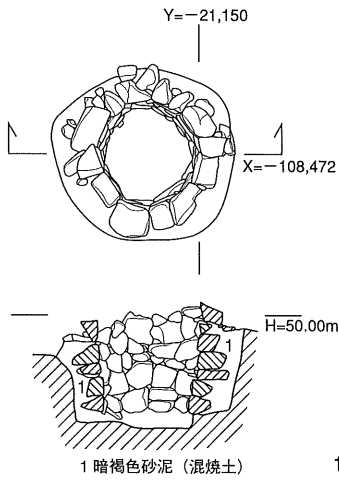

● E区石組土塙 E 22

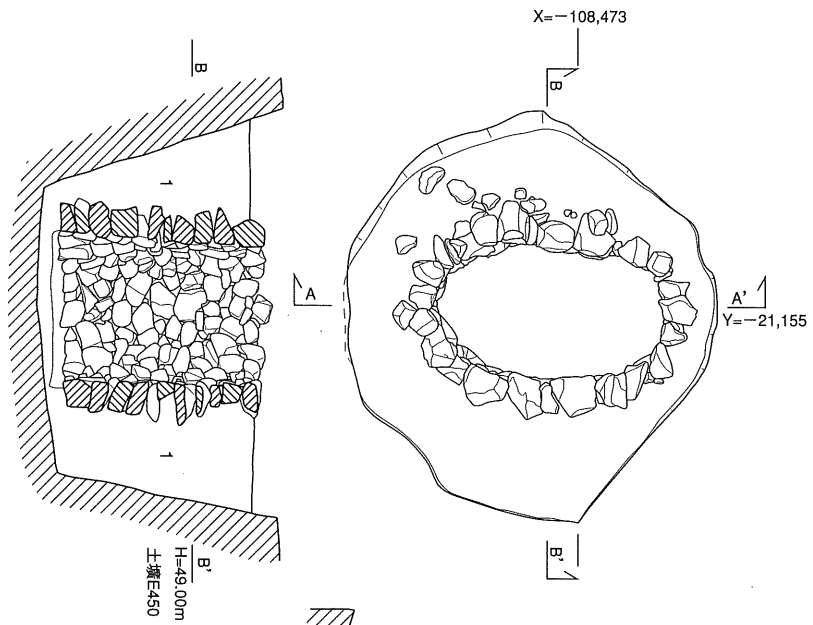

● E区井戸 E 210

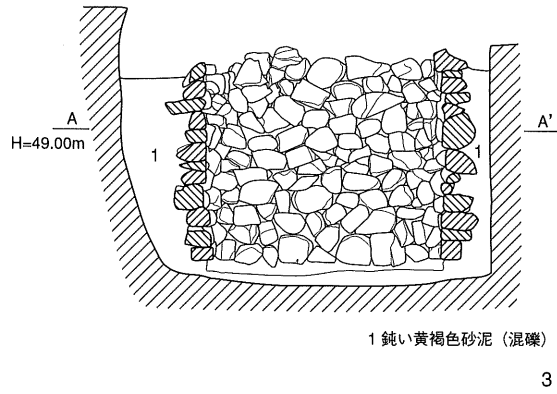
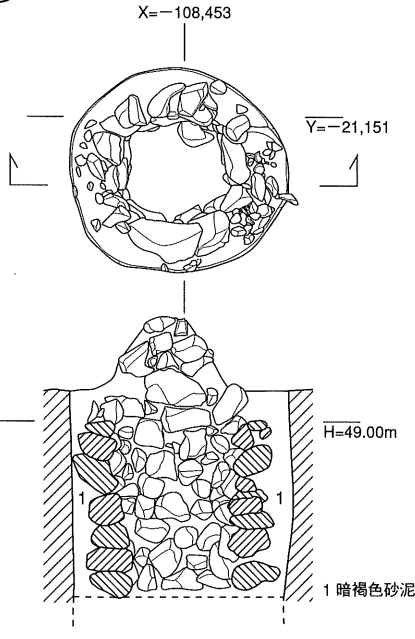

● E区集石 E 70

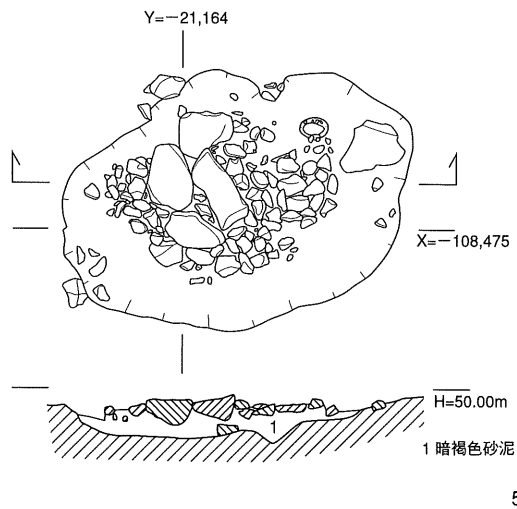

● E区集石 E 3

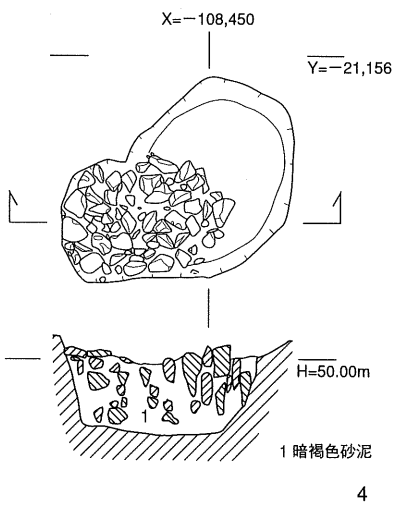

1 E区石組土塙 E 345実測図

2 E区井戸 E 210実測図

3 E区石組土塙 E 22実測図

4 E区集石 E 3実測図

5 E区集石 E 70実測図



桃山時代

Y=-21,140

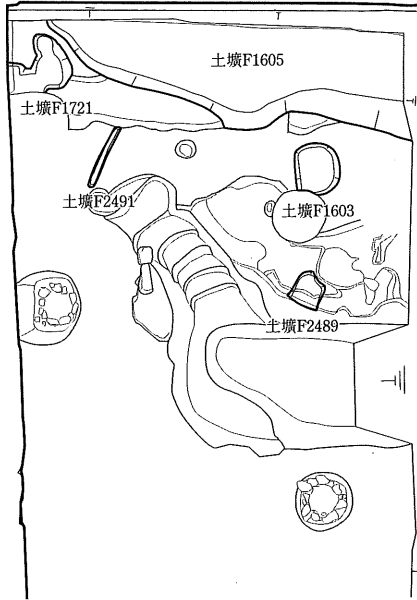

江戸時代前期

Y=-21,140

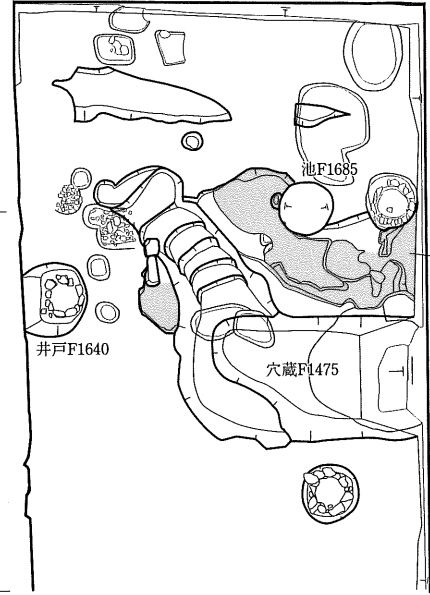

江戸時代中期

Y=-21,140

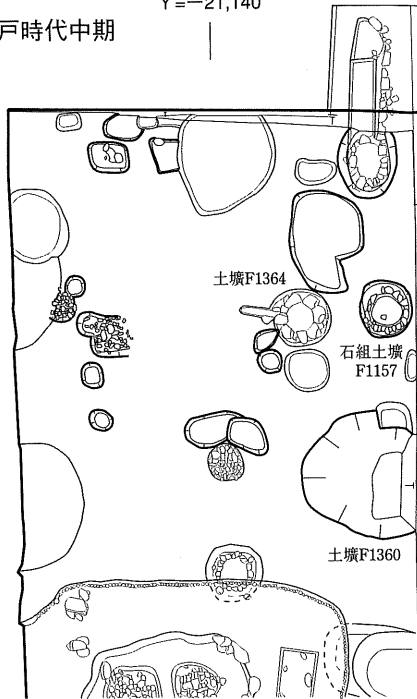

江戸時代後期

Y=-21,140

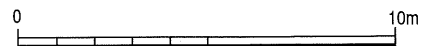
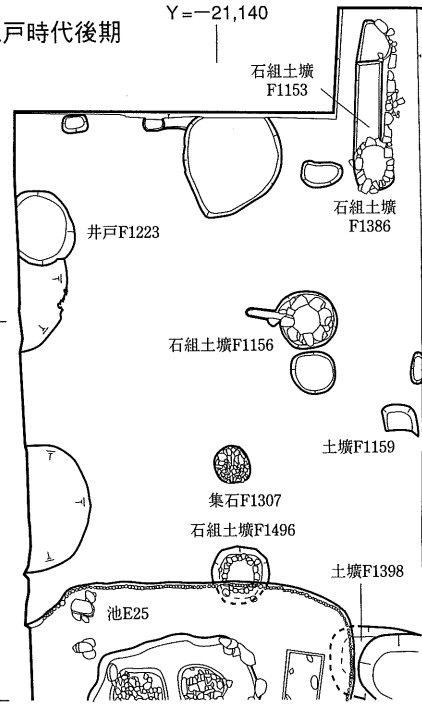

F区北部桃山期～江戸時代後期遺構平面図



Y=-21,180

Y=-21,160 Y=-21,159

X=-108,500

X=-108,520

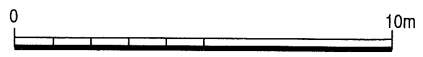
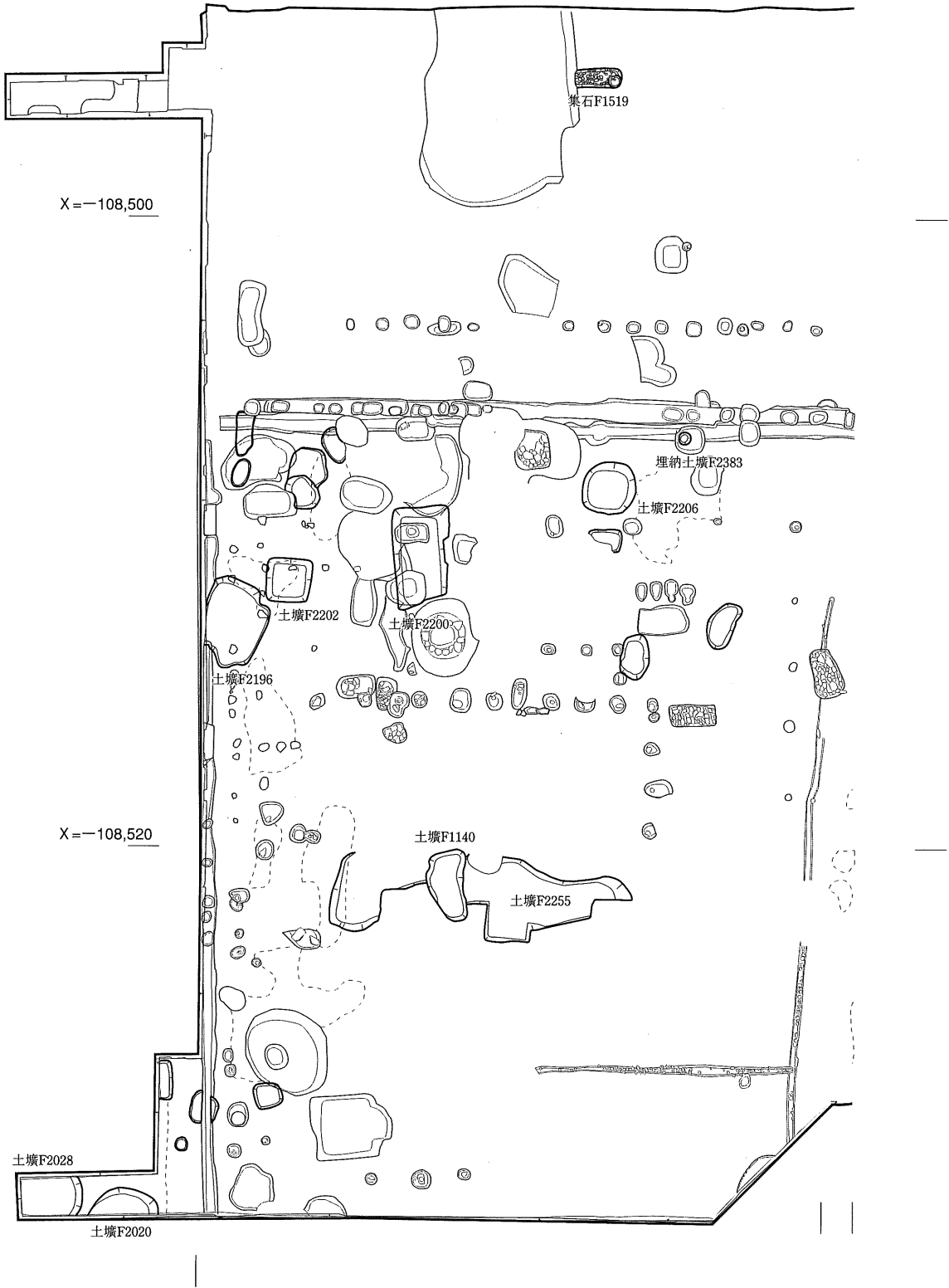

F区西部桃山期遺構平面図

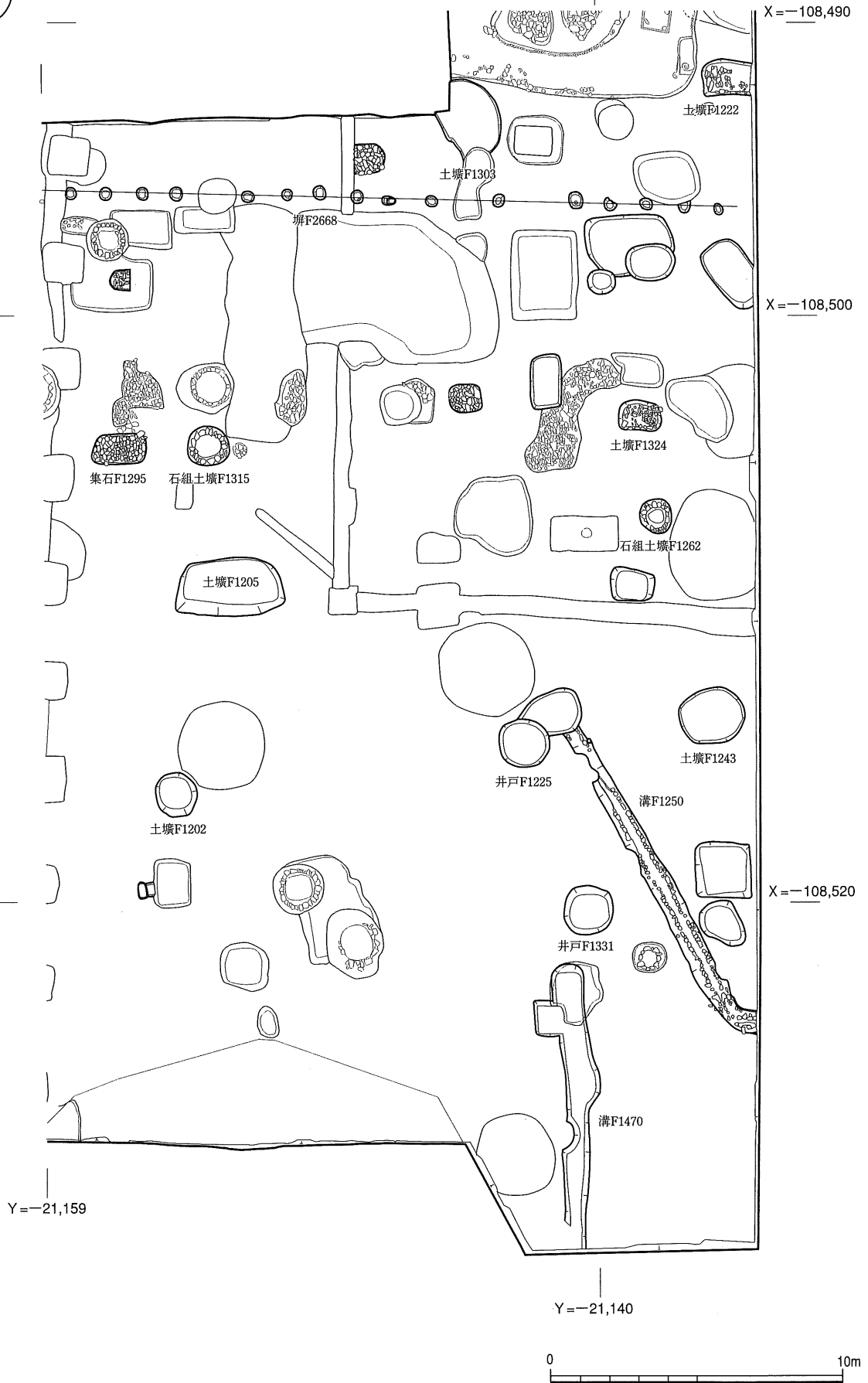

F区東部江戸時代中期遺構平面図

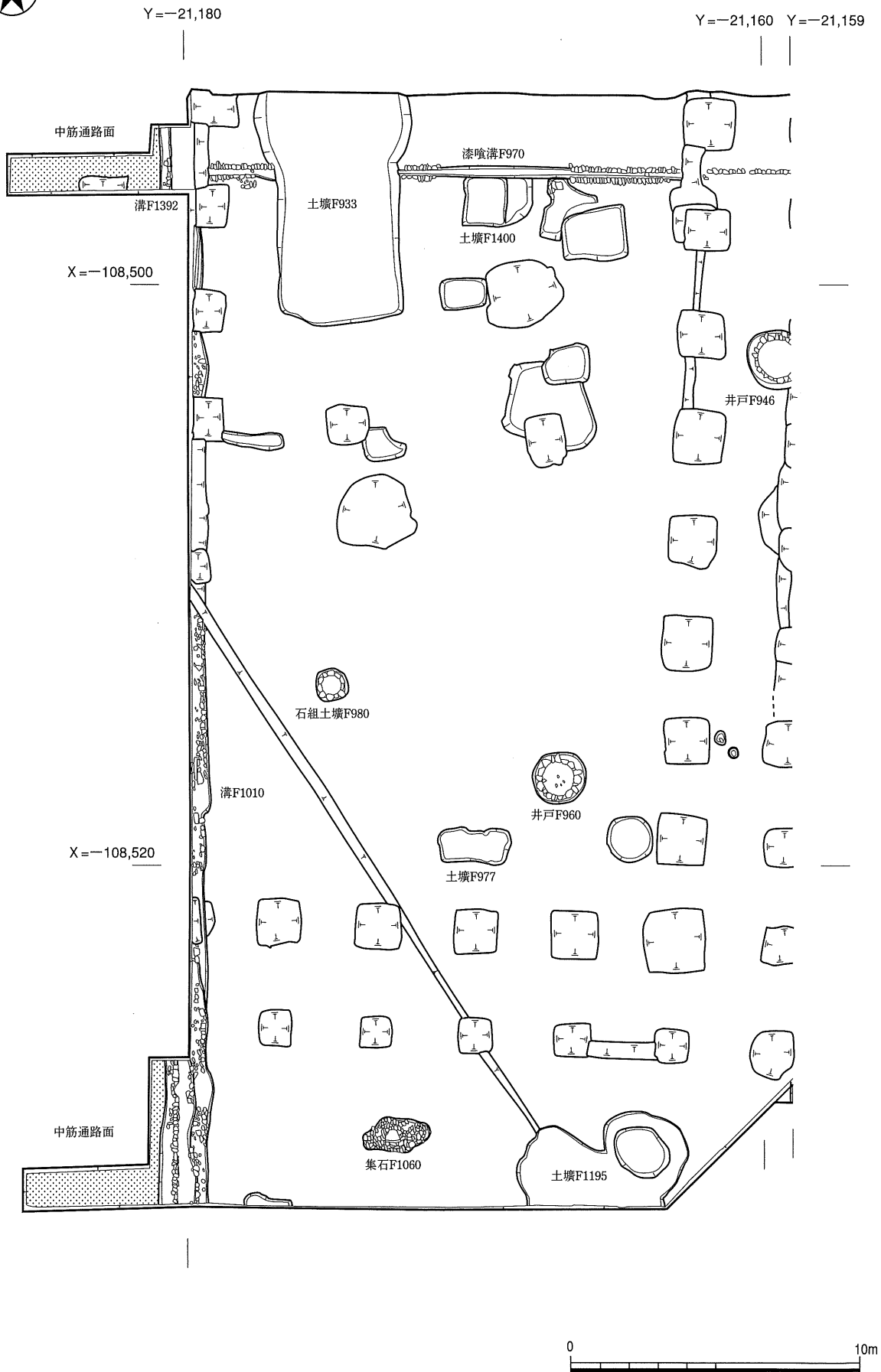

F区西部江戸時代後期遺構平面図

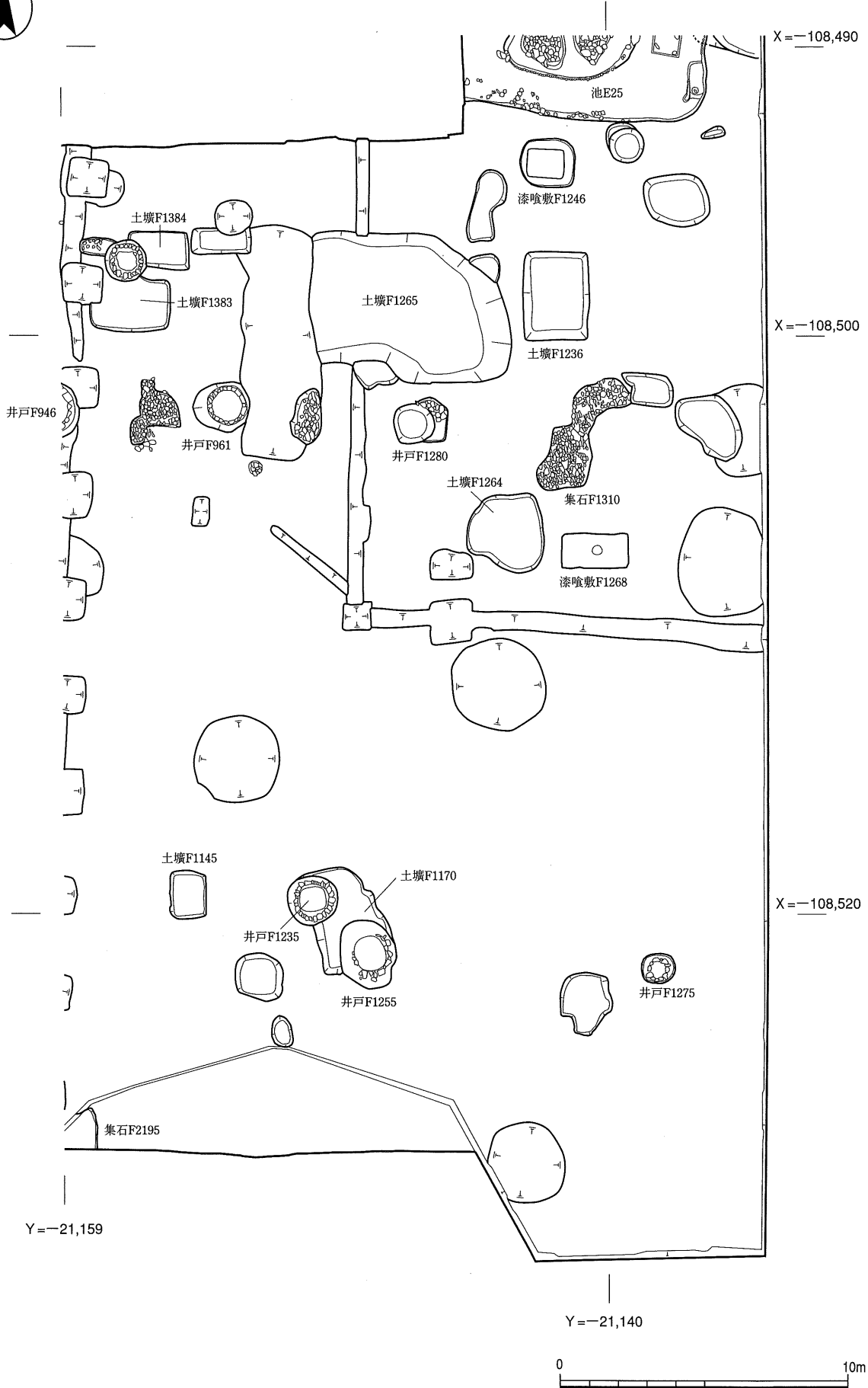

F区東部江戸時代後期遺構平面図







F区建物F2666

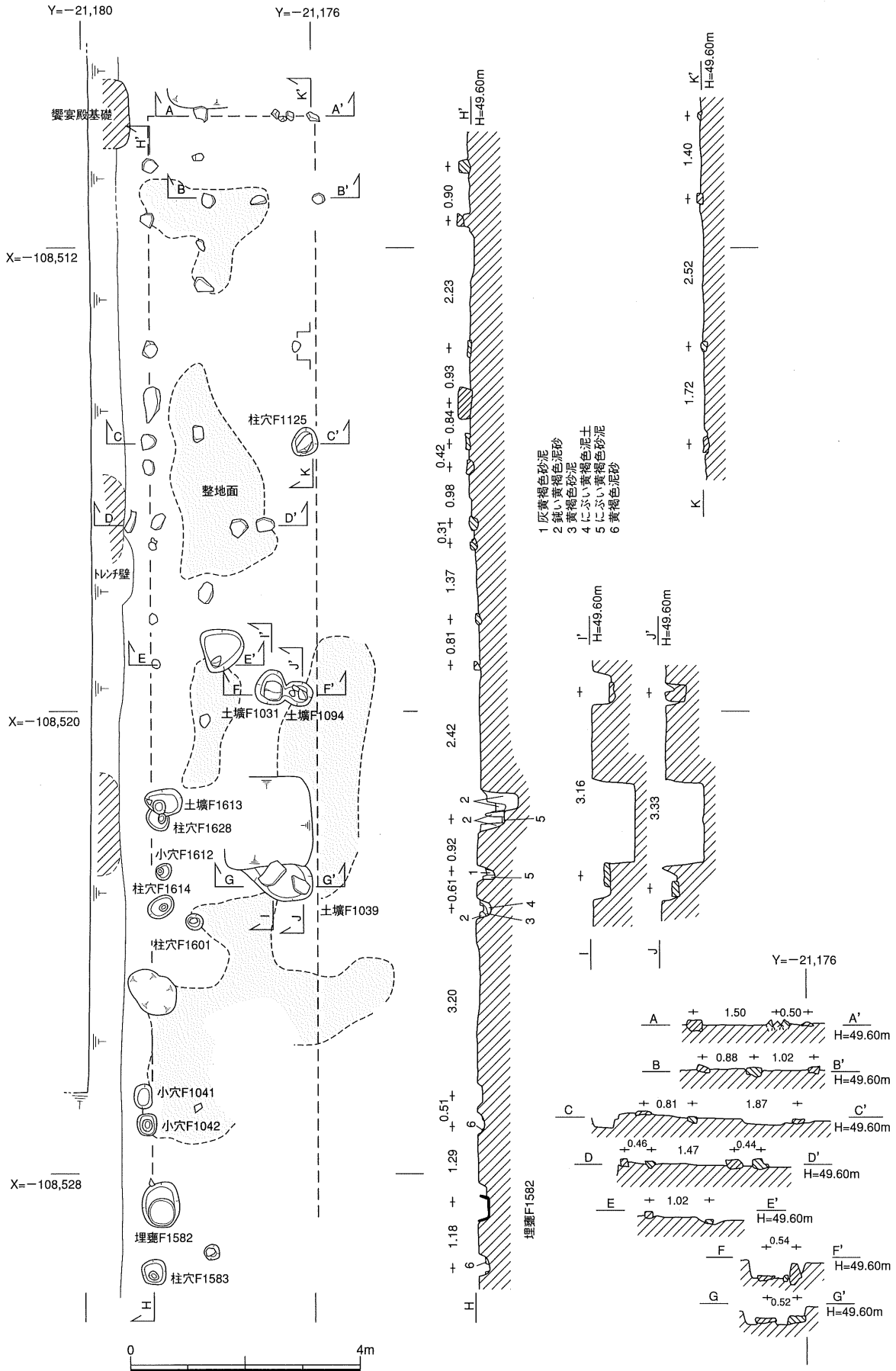

F区建物F2666実測図